

# Kit 1325

**BMW 5-Series, 4-dr Sedan, 04-09**

**BMW 5-Series, 5-dr Touring, 04-09 (without railing)**

**BMW 5-Series, 5-dr Wagon, \*04-10 (without railing)**

\*North America

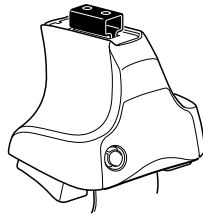

**754** Rapid System  
**480R** Rapid Traverse (North America)

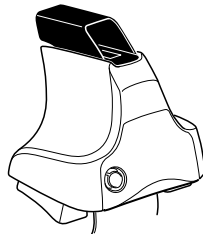
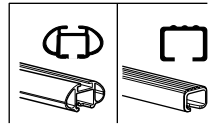

**480** Traverse (North America)

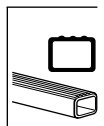

754 Rapid System  
480R Rapid Traverse (North America)

480 Traverse (North America)

(North America)

- 2 x 23 mm
- 2 x 23 mm
- 2 x 23 mm
- 4 x
- 4 x
- 1 x 17 mm
- 2 x 23 mm
- 2 x 23 mm
- 2 x 23 mm
- 2 x 23 mm
- 2 x 23 mm
- 2 x 23 mm
- 2 x

591 x 2

595 x 2

137 x 4

x 1

1

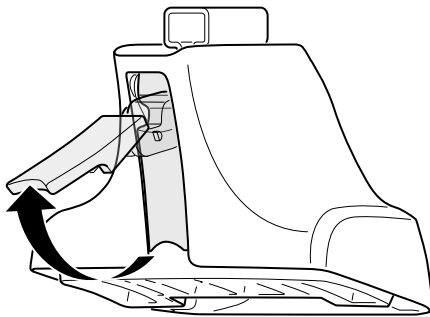

2



754 Rapid System  
480R Rapid Traverse  
(North America)

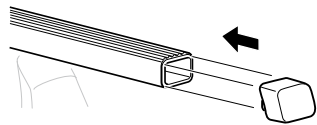
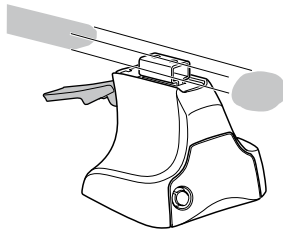

x4

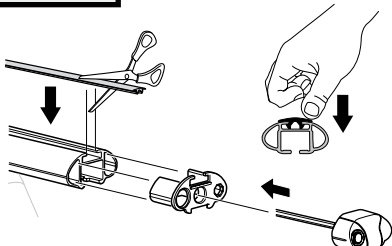

x4

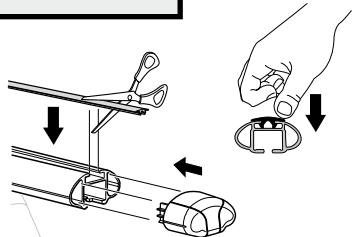
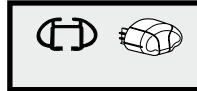

x4



480 Traverse  
(North America)

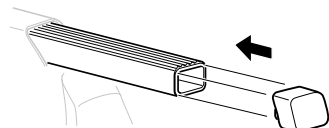
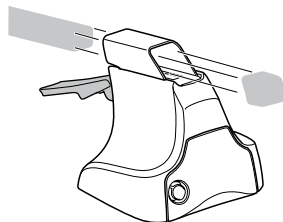

x4

**3**

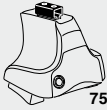

**754** Rapid System

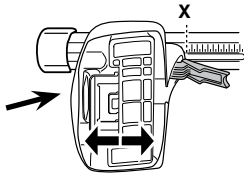

	X
<b>BMW 5-Series, 4-dr Sedan, 04-09</b>	<b>36,5</b>
<b>BMW 5-Series, 5-dr Touring, 04-09 (without railing)</b>	<b>36,5</b>
<b>BMW 5-Series, 5-dr Wagon, *04-10 (without railing)</b>	<b>36,5</b>

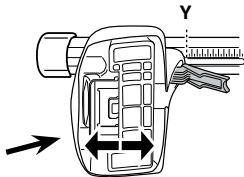

	Y
<b>BMW 5-Series, 4-dr Sedan, 04-09</b>	<b>36</b>
<b>BMW 5-Series, 5-dr Touring, 04-09 (without railing)</b>	<b>34</b>
<b>BMW 5-Series, 5-dr Wagon, *04-10 (without railing)</b>	<b>34</b>

**3**



**480R** Rapid Traverse



**480** Traverse

**(North America)**

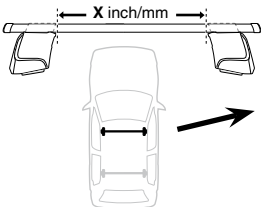

	X inch	X mm
<b>BMW 5-Series, 4-dr Sedan, 04-09</b>	<b>40"</b>	<b>1016 mm</b>
<b>BMW 5-Series, 5-dr Touring, 04-09 (without railing)</b>	<b>40"</b>	<b>1016 mm</b>
<b>BMW 5-Series, 5-dr Wagon, *04-10 (without railing)</b>	<b>40"</b>	<b>1016 mm</b>

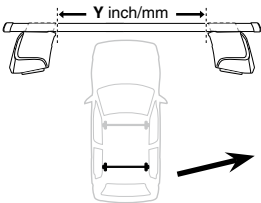

	Y inch	Y mm
<b>BMW 5-Series, 4-dr Sedan, 04-09</b>	<b>39 3/4"</b>	<b>1011 mm</b>
<b>BMW 5-Series, 5-dr Touring, 04-09 (without railing)</b>	<b>39"</b>	<b>991 mm</b>
<b>BMW 5-Series, 5-dr Wagon, *04-10 (without railing)</b>	<b>39"</b>	<b>991 mm</b>

**4**

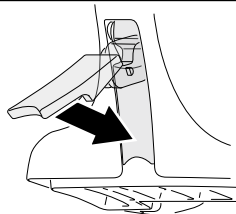

# 5

BMW 5-Series, 4-dr Sedan, 04-09

BMW 5-Series, 5-dr Touring, 04-09 (without railing)

BMW 5-Series, 5-dr Wagon, \*04-10 (without railing)

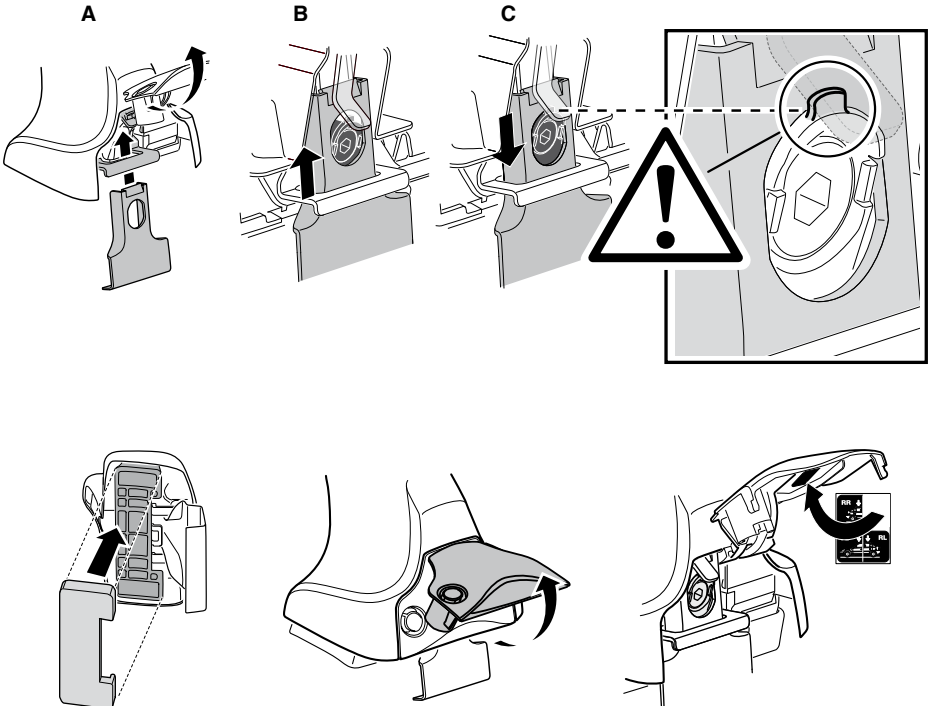
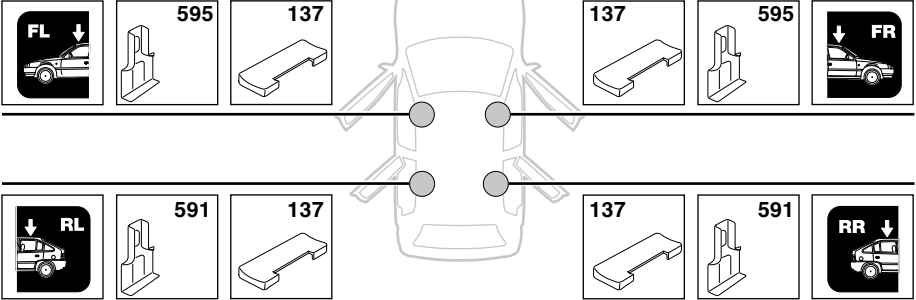

6

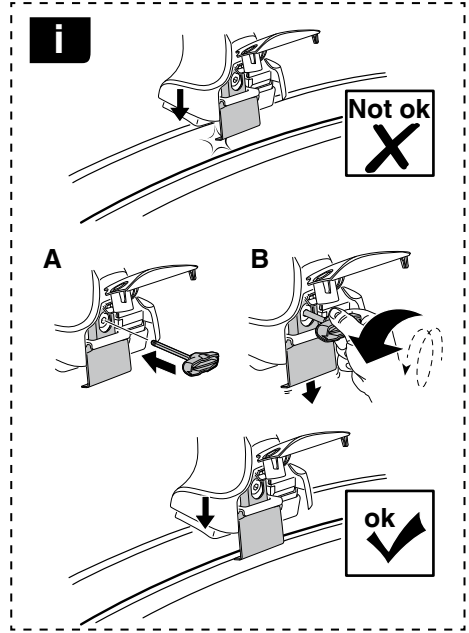
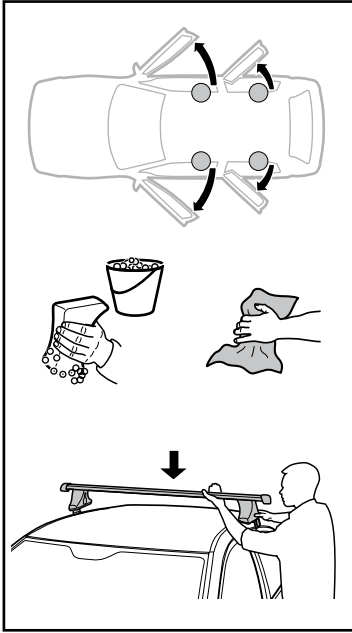

	X mm	Y mm	X inch	Y inch
<b>BMW 5-Series, 4-dr Sedan, 04-09</b>	270 mm	750 mm	10 <sup>5</sup> / <sub>8</sub> "	29 <sup>1</sup> / <sub>2</sub> "
<b>BMW 5-Series, 5-dr Touring, 04-09 (without railing)</b>	270 mm	700 mm	10 <sup>5</sup> / <sub>8</sub> "	27 <sup>1</sup> / <sub>2</sub> "
<b>BMW 5-Series, 5-dr Wagon, *04-10 (without railing)</b>	270 mm	700 mm	10 <sup>5</sup> / <sub>8</sub> "	27 <sup>1</sup> / <sub>2</sub> "

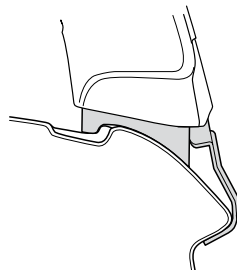
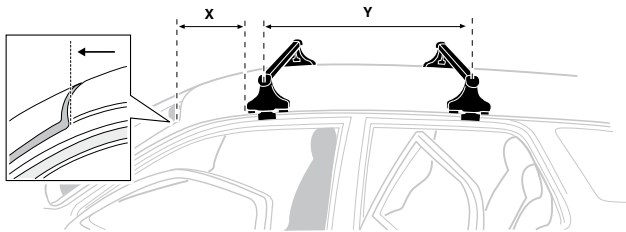

7

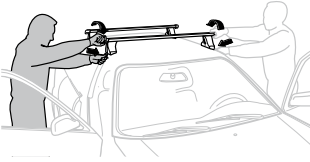

**GB/US** Tighten alternately  
**D** Die Schrauben abwechselnd anziehen  
**F** Serrer alternativement chaque côté  
**NL** Afwisselend aan de linker- en de rechterkant aandraaien  
**I** Alternare il serraggio delle viti  
**E** Apertar alternativamente  
**PT** Aperte alternadamente  
**S** Dra åt växelvis  
**FIN** Kierrä vuorotellen  
**EST** Pinguldage vaheldumisi  
**LAT** Pievelciēt pamišus  
**LIT** Užsukinėkite pakaitomis  
**PL** Śruby dokręcaj naprzemiennie  
**RU** Затягивайте попеременно

**CZ** Pokrétla bagażnika dokręcaj dokręcaj naprzemiennie.  
**SK** Doťahujte striedavo  
**SLO** Privijajte izmenično.  
**HR** Naizmjenično zategnite  
**HU** Egymástól függetlenül szorítandó  
**GR** Σφιγγεται εναλλάξ  
**TR** Dönüşümlü sıkın

**中文** 交替拧紧

**한국어** 번갈아 가며 조이십시오.

**日本語** 交互に締め付けてください。

**ไทย** ชั้้นในแบบสลับ

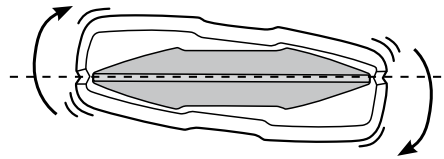
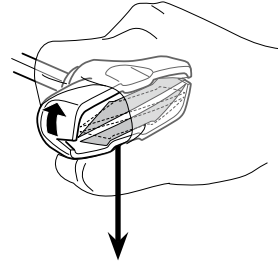
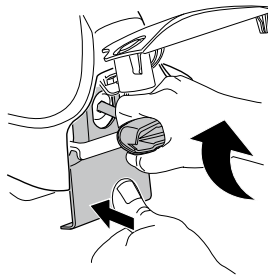
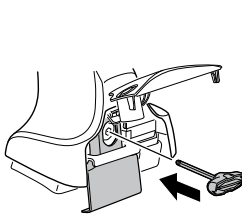

≈ 3 Nm

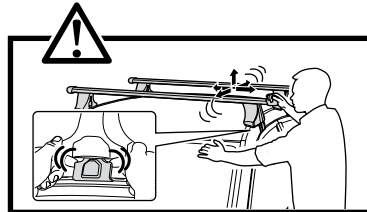
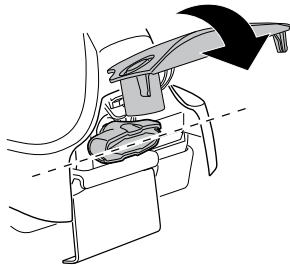

8



x1  
17 mm

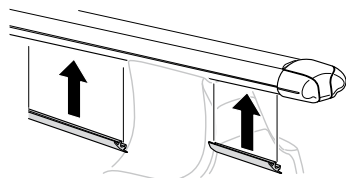

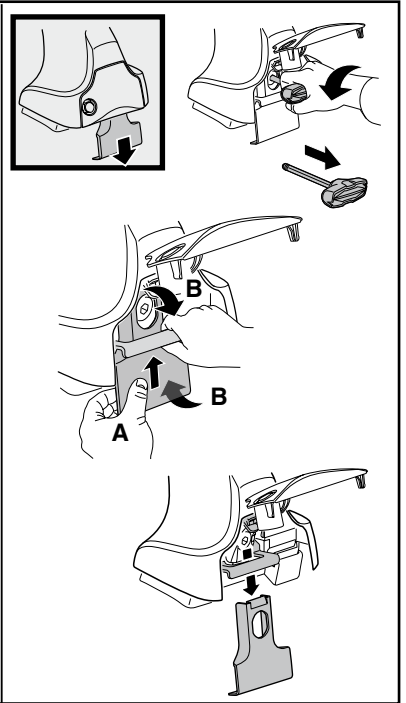
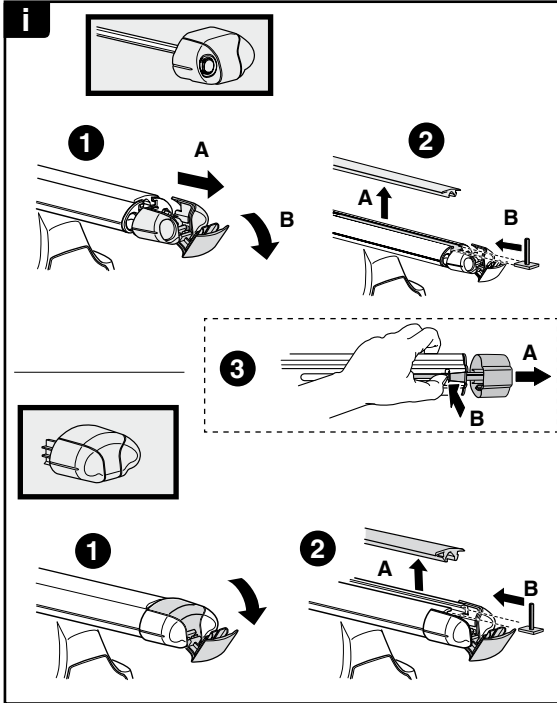
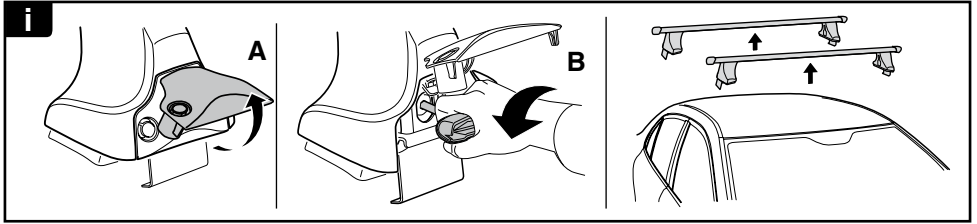

**THULE**  
SWEDEN  
**ONE  
KEY  
SYSTEM**

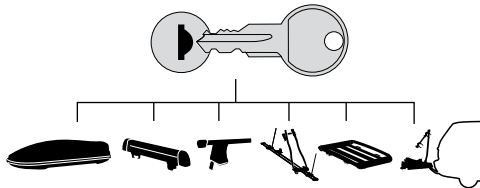

**544** (x4)

**596** (x6)

**588** (x8)

NA **510** (x10)

EUR **452** (x12)

ASIA

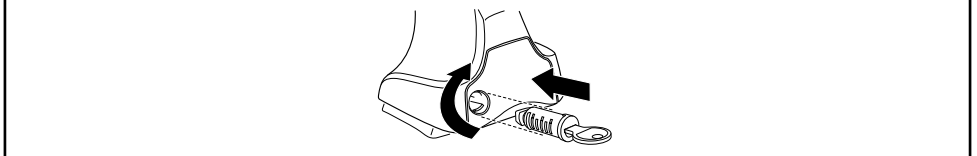

WW ▶ Thule Sweden AB, Box 69, 330 33 Hillerstorp, SWEDEN  
NA ▶ Thule Inc., 42 Silvermine Road, Seymour, Connecticut 06483, USA

info@thule.com  
customer.service@thule.com

www.thule.com

503-1325-04