



RHINO-RACK

SXBS37

SXBS38

Maximum load capacity: 100kg (220lbs)

Recommendations:

It is essential that all bolt connections be checked after driving a short distance when you first install your crossbars. Bolt connections should be checked and lubricated at regular intervals (probably once a week is enough, depending on road conditions, usage, loads and distances travelled). You should also check the crossbars each time they are refitted. Make sure to fasten your load securely. Please ensure that all loads are evenly distributed and that the centre of gravity is kept as low as possible.

Crossbars must be removed when putting vehicle through an automatic car wash.

Use only non-stretch fastening ropes or straps.

Caution: The handling characteristics of the vehicle changes when you transport a load on the roof. For safety reasons we recommend you exercise extreme care when transporting wind-resistant loads. Special consideration must be taken into account when cornering and braking.

Off-road Load Rating:

When crossbars are to be used in off-road conditions, please build a safety factor of 1.5 into this load limit for off-road use, two crossbars = **66kg (145lbs)**. Although the crossbars are tested and approved to AS1235-2000, off-road conditions can be much more rigorous. However, increasing the number of crossbars does not increase the vehicles maximum permissible roof loading.

Note for Dealers and Fitters:

It is your responsibility to ensure instructions are given to the end user or client.

Rhino-Rack
3 Pike Street, Rydalmere,
NSW 2116, Australia.
(Ph) (02) 9638 4744
(Fax) (02) 9638 4822

Document No: R280
Prepared By: Craig Jones
Authorised By: Chris Murty

Issue No: 01
Issue Date: 06/05/2013

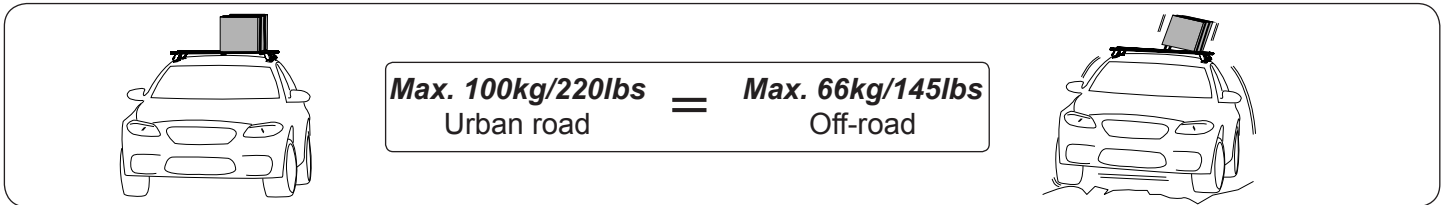
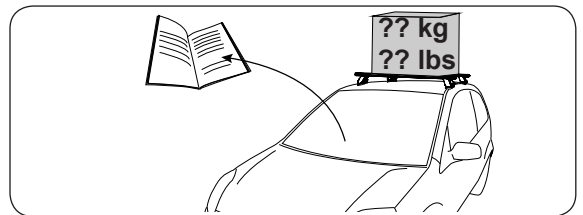
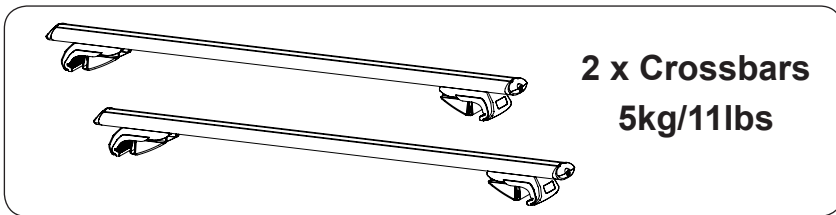
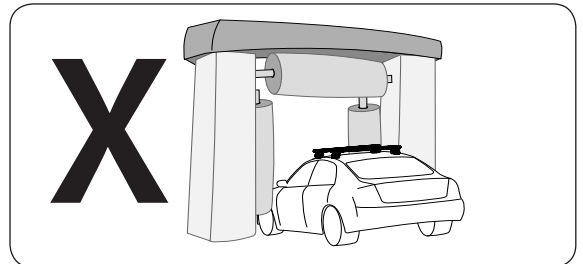
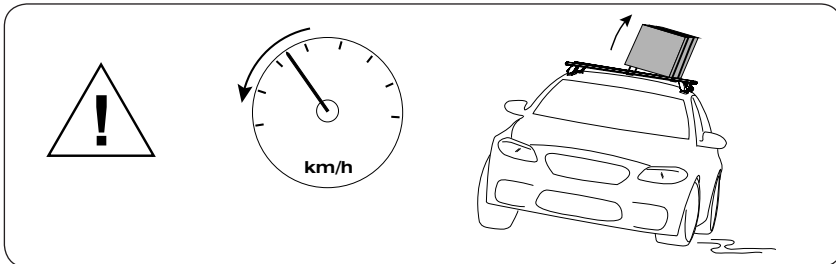
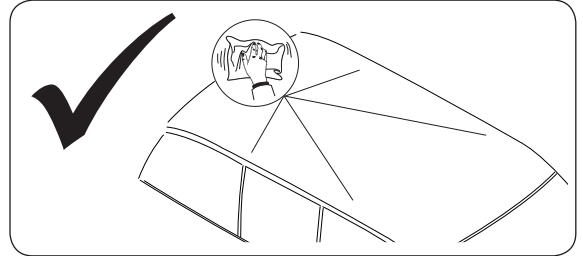
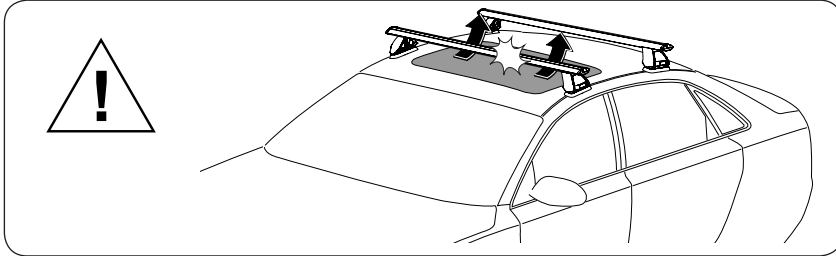
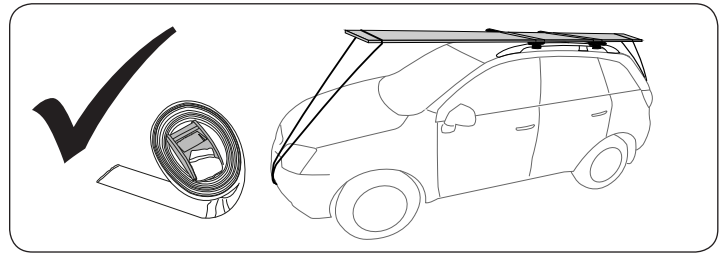
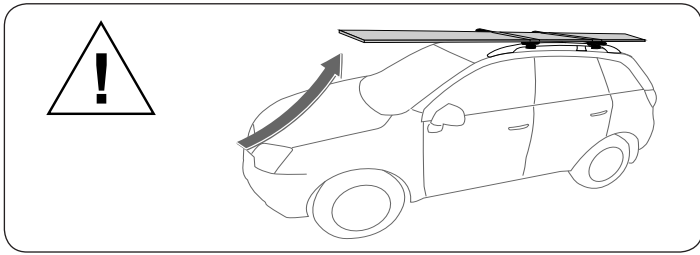

WARNING! Important Load Carrying Instructions

With utility vehicles, the cabin and the canopy move independently. Roof racks and vehicle can be damaged if the item transported is rigidly fixed at points on both the cabin and canopy. Instead, rigidly fix to either the cabin roof racks or the canopy roof racks.

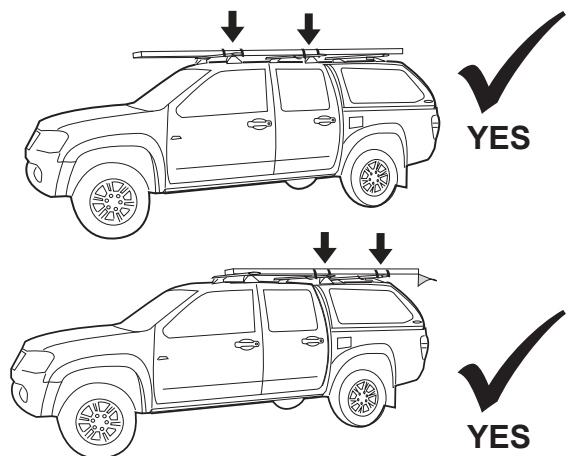
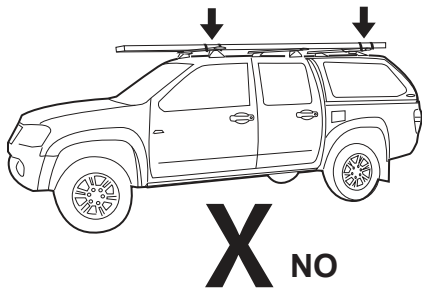

- Please refer to your vehicle manufacturers handbook for maximum roof load capacity.
- Any load transported on Roof Racks must be evenly distributed.
- Instructions are to remain with the vehicle.
- Do not attempt to fit the roof racks to your vehicle unless you fully read and understand the fitting instructions provided.
- Please direct any questions to the dealer from where the roof racks were purchased.
- Check the contents of this kit before commencing fitment and report any discrepancies.



Parts List

Item	Component	Qty.	Part No.
1	Buffer strip	2	R011
2	Crossbar 1140mm (44,7/8") SXBS38	2	A045
2	Crossbar 1260mm (49,39/64") SXBS37	2	A046
3	Locking end cap	4	M076/C192
4	Key	3	-
5	Underbar strip	4	R034
6	SXB Leg	4	SUB0508
7	5mm Torque allen key	1	TORKEY-L
8	Fitting instruction	1	R280

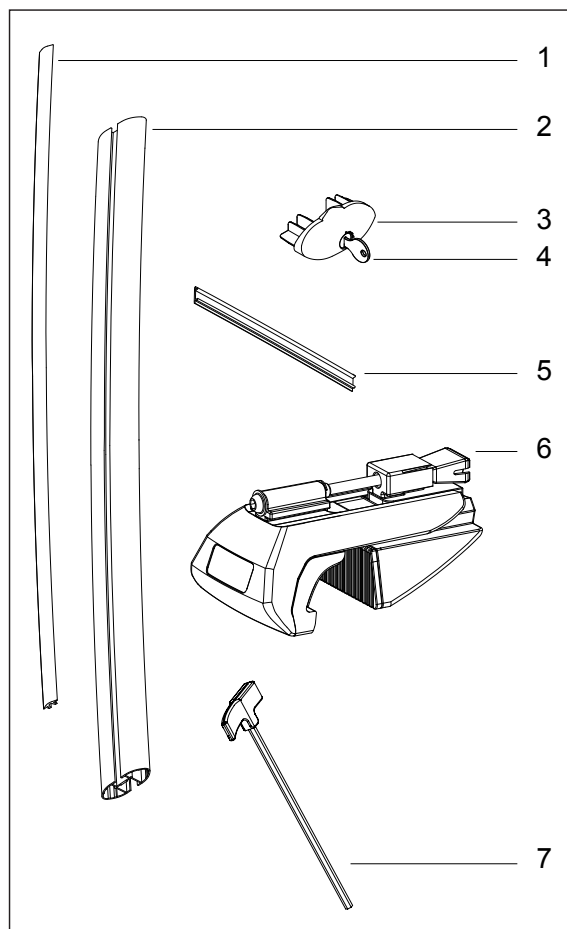

Tools required:

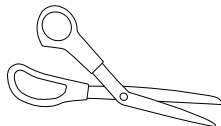
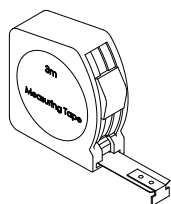

1

Item 1

Item 2

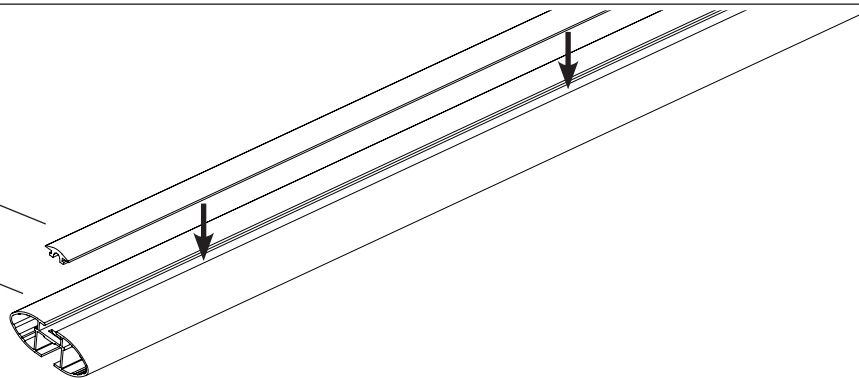

2

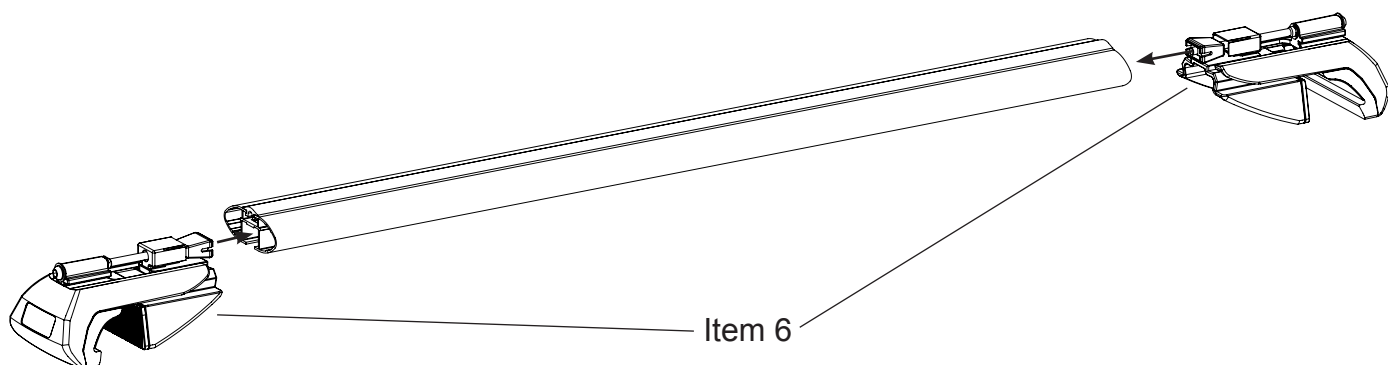



- 3** Gap on underside of crossbar can be increased in length if required. Use pliers to remove material. Place crossbar assembly onto the roof rails of the vehicle.

