



RHINO-RACK

Aerodynamic & Heavy Duty Roof Rack Systems

RTS517 MITSUBISHI Challenger - Two Cross Bar Track Mount System

Important: Please read these instructions carefully prior to installation.
Please refer to your fitting instruction to ensure that the roof racks are installed in the correct locations.
Check the contents of kit before commencing fitment and report any discrepancies.
Place these instructions in the vehicle's glove box after installation is complete.

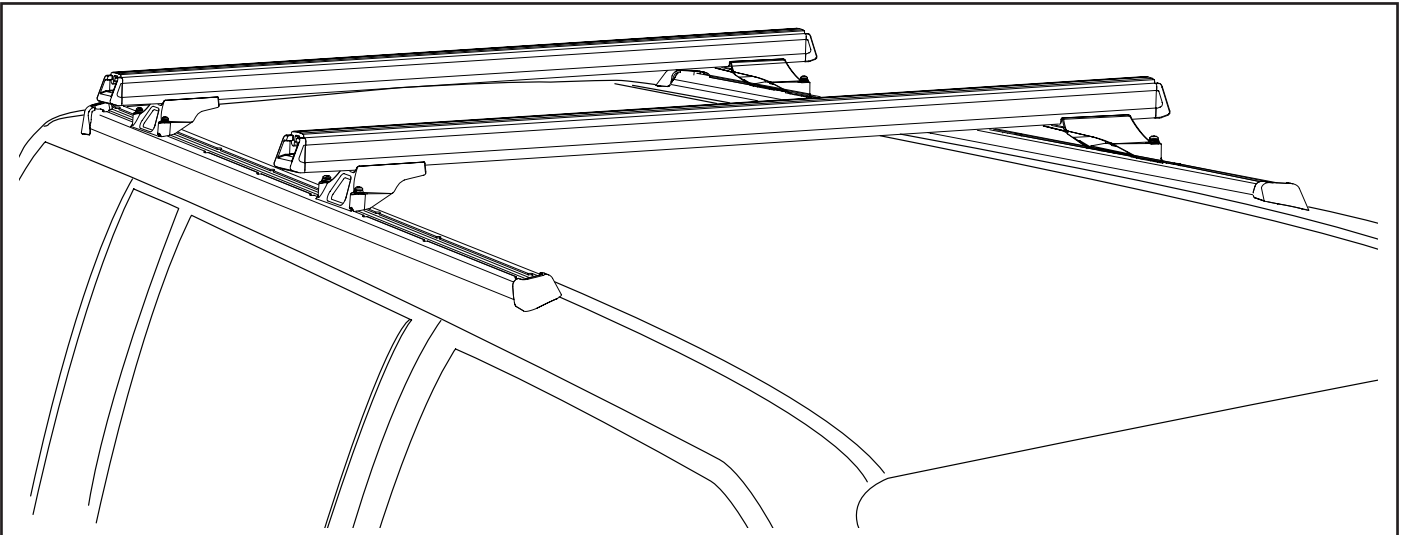

Care Instruction: Wash vehicle roof prior to installing Rhino Tracks.

Important Information

Maximum carrying capacity: 100kg

Recommendations:

It is essential that all bolt connections be checked after driving a short distance when you first install your cross bars. Bolt connections should be checked again at regular intervals (probably once a week is enough, depending on road conditions, usage, loads and distances travelled). You should also check the cross bars each time they are re-fitted.

Make sure to fasten your load securely. Please ensure that all loads are evenly distributed and that the centre of gravity is kept as low as possible.

Use only non-stretch fastening ropes or straps.

Sensitivity to cross winds, behaviour in curves and braking.

The handling characteristics of the vehicle, changes when you transport a load on the roof. For safety reasons, we recommend you exercise extreme care when transporting wind-resisting loads; special consideration must be taken into account when braking.

Please remove cross bars when putting vehicle through an automatic car wash.

Load Ratings:

Maximum permissible load is 100kg per pair of cross bars (include the weight of the cross bars, 5kg). When cross bars are to be used in off-road conditions, please build a safety factor of 1.5 into this load limit. Although the cross bars are tested and approved to AS1235-2000, Australian road conditions can be much more rigorous. However, increasing the number of cross bars does not increase the vehicles maximum permissible roof loading.

Note for Dealers and Fitters:

It is your responsibility to ensure instructions are given to the end user or client.

Rhino-Rack
3 Pike Street, Rydalmere,
NSW 2116, Australia.
(Ph) (02) 9638 4744
(Fax) (02) 9638 4822

Document No: RR-168
Prepared By: Craig Jones
Authorised By: Gary England

Issue No: 01
Issue Date: 16/01/2008

These instructions remain the property of Rhino-Rack Australia Pty. Ltd. and may not be used or changed for any other purpose than intended.



RTS517 MITSUBISHI Challenger Two Cross Bar Track Mount System

Parts List

Item	Component Name	Qty	Part No.
1	Rubber End Cap FL/RR	2	M277
2	Rubber End Cap FR/RL	2	M278
3	Track 1800mm RIGHT	1	A408
4	Track 1800mm LEFT	1	A408
5	Heavy Duty Rubber Buffer 1375mm	2	R004
6	Heavy Duty Crossbar End Cap	4	M002
7	Heavy Duty Crossbar 1375mm	2	A020
8	M10 Channel Nut	4	N024
9	M6 x 35mm Button Security Screw	8	B092
10	M6 Spring Washer	8	W004
11	M6 x 12.5mm Flat Washer	8	W003
12	RLTP Track Mount Leg	4	M057
13	M6 x 21.43mm Brass Hex Nut	8	N009
14	M10 x 38mm Flat Washer	4	W022
15	M10 Internal Shakeproof Washer	4	W021
16	M10 x 25mm Hex Bolt	2	B071
17	Rivet 5mm	20	H005
18	5mm Security Allen Key	1	SECKEY-S
19	Fitting Instruction	1	RR-168

Tools Required:

Pneumatic or Concertina
Rivet gun.
Masking tape.
Rubber Mallet.
Power or Cordless drill.

WD-40 or liquid soap.
5mm drill bit.
Vacuum cleaner.
Cold galvanizing solution & small brush.
Selleys Butyl Mastic.

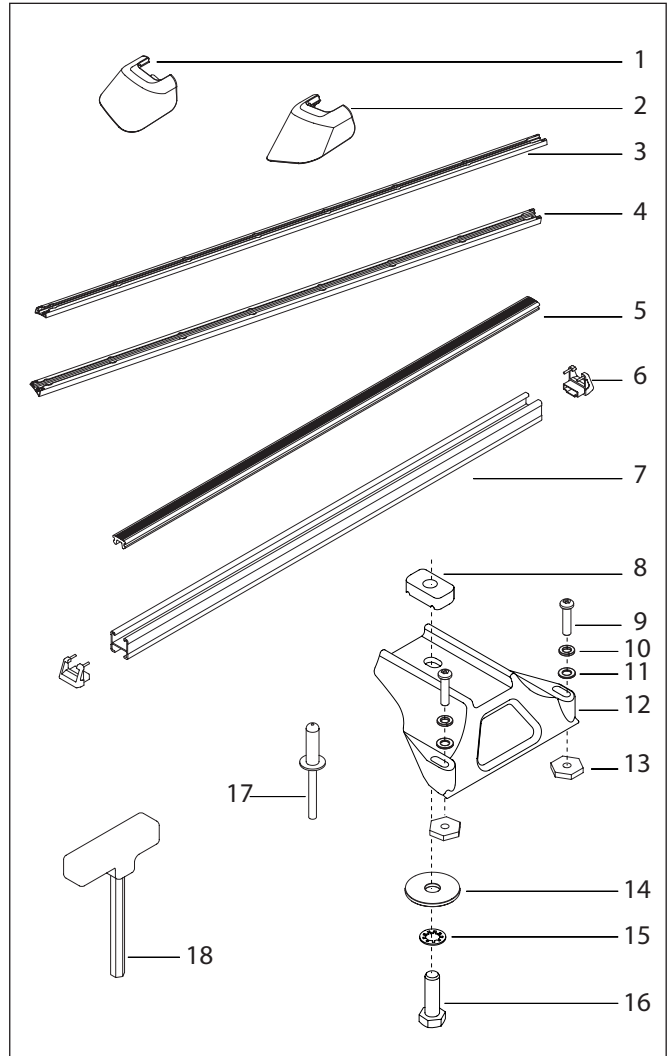

SPECIAL NOTE:

Assistance by a second person is required to maintain accurate alignment of the Track extrusion while holes are marked out and drilled.

IMPORTANT Care Instruction:

Wash the roof prior to fitting the track mount system, especially the area the track will be mounting to. PLEASE READ THROUGH INSTRUCTIONS BEFORE FITTING.

Tracks are to be mounted on the outer surface of the roof.

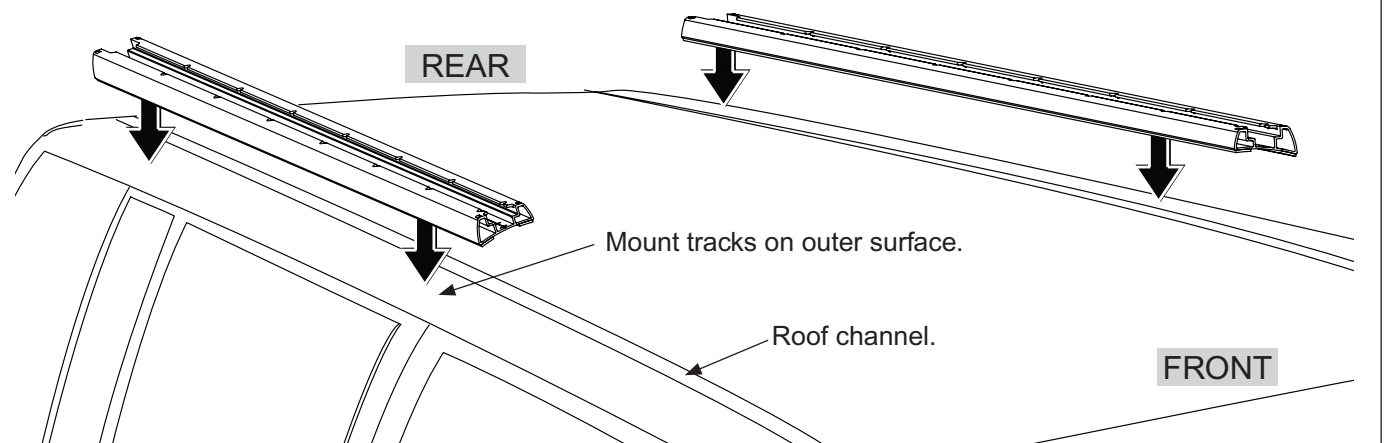



RTS517 MITSUBISHI Challenger Two Cross Bar Track Mount System

1

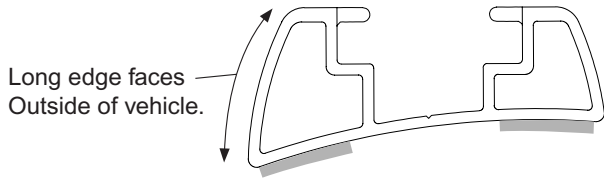

Long edge faces
Outside of vehicle.

The track extrusions are Left and Right handed. Each track has two large cut outs at one end, this denotes the **FRONT** of the vehicle. The single large cut out denotes the **REAR**.

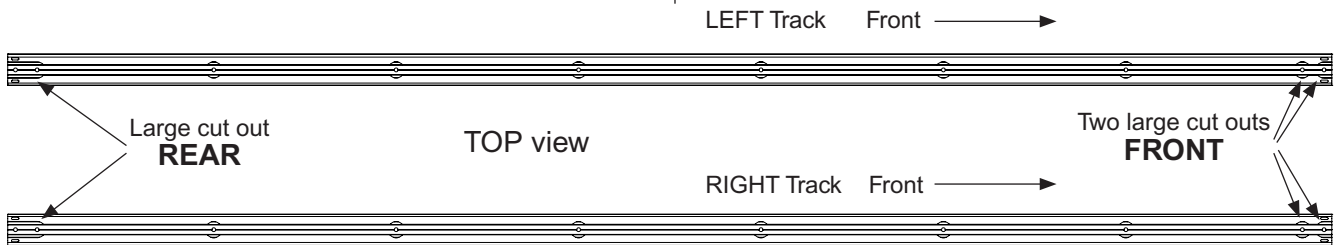

LEFT Track Front →

Large cut out
REAR

TOP view

Two large cut outs
FRONT

RIGHT Track Front →

NOTE: WE RECOMMEND THAT YOU COMPLETELY INSTALL ONE TRACK AT A TIME.

2.

NOTE: (P1) refers to the person spot drilling.
(P2) refers to the person assisting.

- a. **FRONT** of track to be 4-5mm from outer edge of roof channel radius. **REAR** of track to be 0-1mm from outer edge of roof channel radius.
- b. Maintain downward pressure on the track while spot drilling all holes.
- c. Person one (P1), with the assistance of a second person (P2). Hold the track firmly in position. Spot drill the first six holes. P2 to hold the track and maintain alignment of the sixth hole as P1 moves around towards the rear of the track. P2 and P1 hold the track while maintaining sixth hole alignment and P1 to continue spot drilling holes 7 - 10.

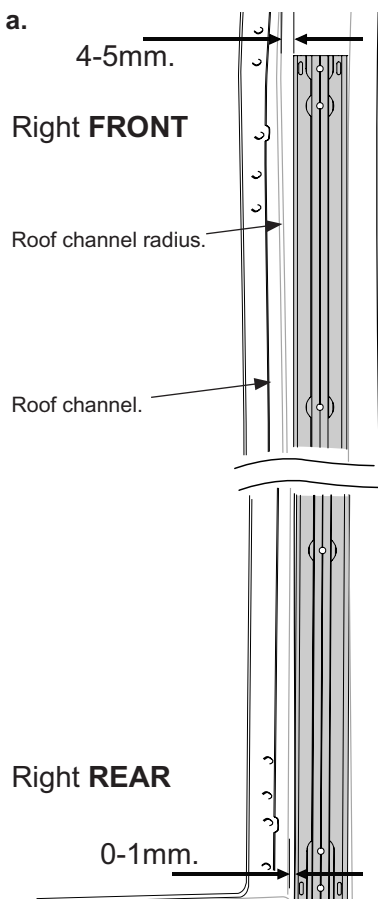

Right **FRONT**

Roof channel radius.

Roof channel.

Right **REAR**

0-1mm.

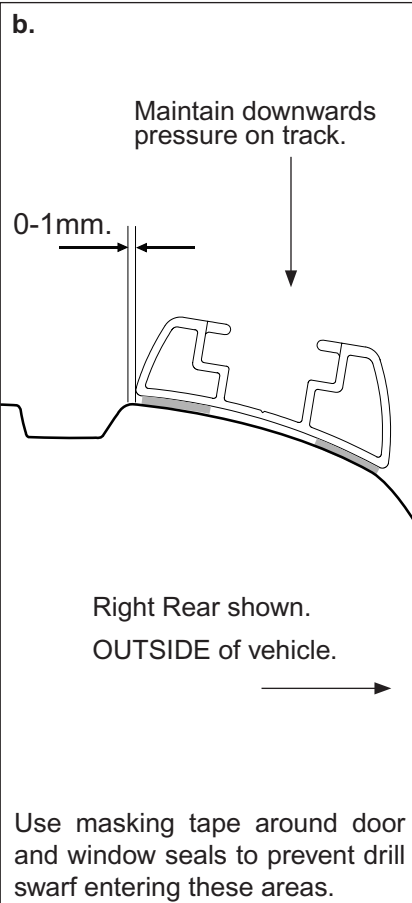

b.

Maintain downwards
pressure on track.

0-1mm.

Right **REAR** shown.
OUTSIDE of vehicle.

Use masking tape around door
and window seals to prevent drill
swarf entering these areas.

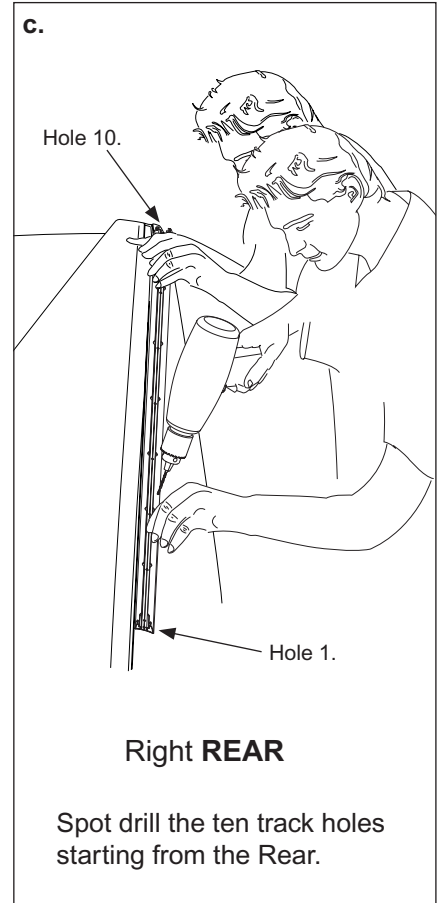

c.

Hole 10.

Hole 1.

Right **REAR**

Spot drill the ten track holes
starting from the Rear.



RTS517 MITSUBISHI Challenger Two Cross Bar Track Mount System

3



All ten holes can now be drilled through. A drill stop is recommended to prevent drilling through the hood lining on the inside. **Make sure that when drilling you hold the drill perpendicular to the roof angle.** The roof skin is approx. 1-2mm thick.

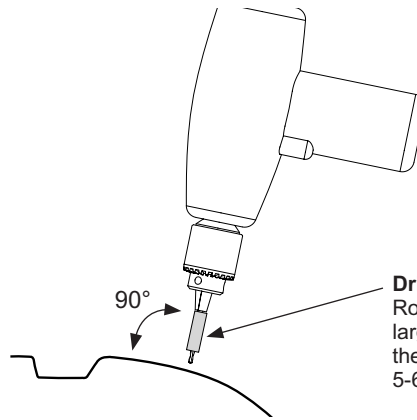

Drill stop.
Round piece of wood of larger outer diameter than the hole being drilled. 5-6mm hole through centre.

4

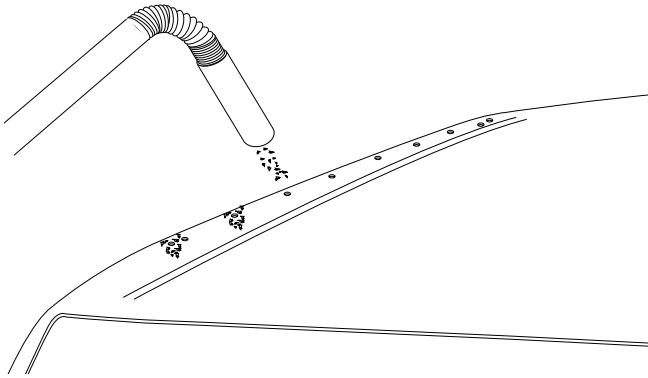

Use a vacuum to remove swarf to eliminate scratching. Wipe clean the installation area of the roof.

5

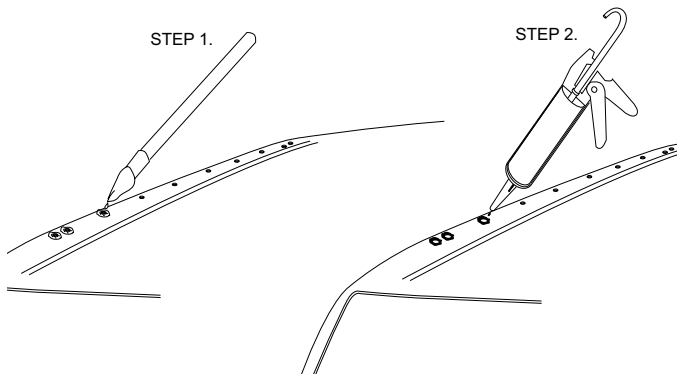

Apply a liberal amount of cold galvanizing solution to the inside and surrounds of all holes. Allow cold galvanizing solution to dry, three to four minutes, then apply a liberal amount of Selley's Butyl Mastic in and around each hole.

6

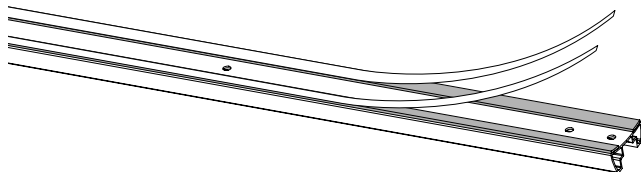

Peel the white backing strip off the track foam tape.



RTS517 MITSUBISHI Challenger Two Cross Bar Track Mount System

7

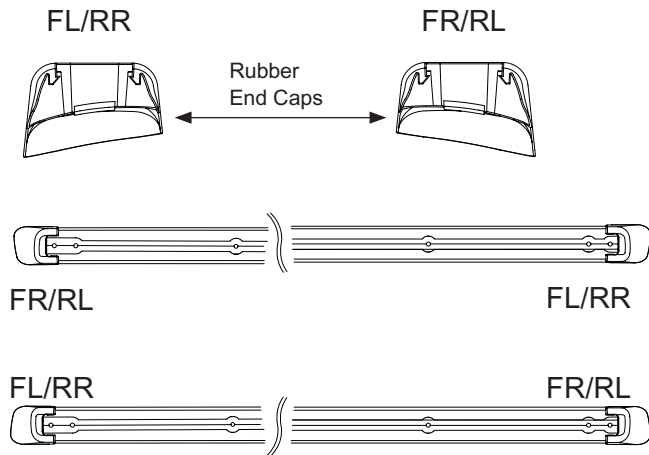

Fit the rubber end caps to the tracks. The end caps are marked on the underside to denote their position.

FL/RR: Front Left track and Rear Right track.

FR/RL: Front Right track and Rear Left track.

For ease of end cap installation use WD-40 or liquid soap to lubricate the locating fingers. Push the fingers through the slots in the track.

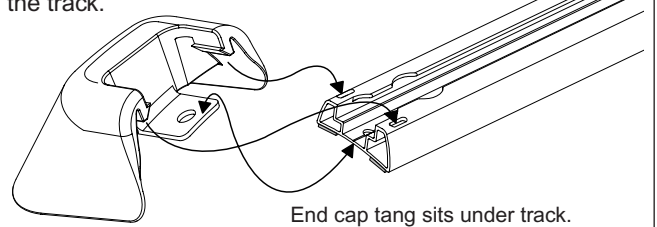

8

Line up and place all 10 rivets in their respective holes. With the assistance of a second person to maintain track alignment start riveting from the centre rivet. Follow the numerical riveting order as shown below.

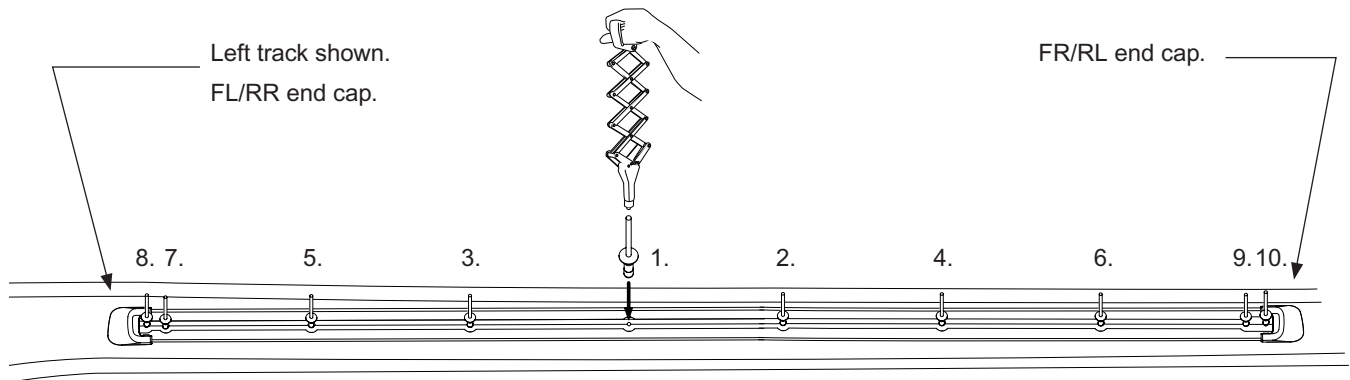

9

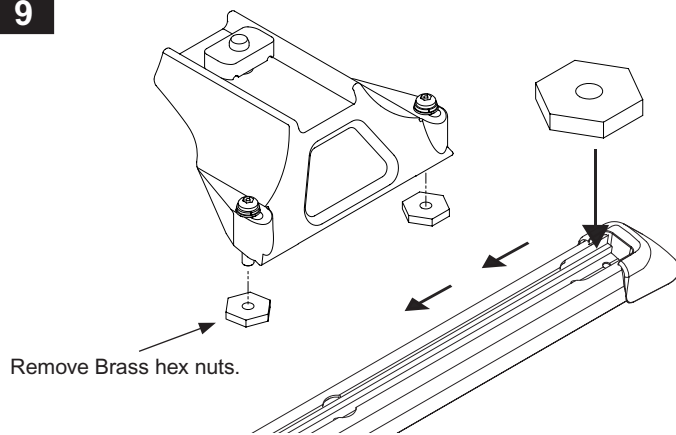

Unscrew the brass hex nuts from the RLTP leg. Place the hex nuts off each RLTP leg into the large cut out at Rear of track and slide along to desired position. The legs will be fitted in place after the cross bars are attached.

10

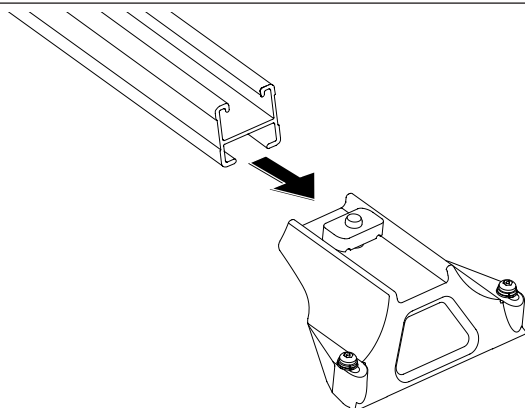

Slide the cross bar onto the leg and locate with the M10 channel nut. Leave untensioned at this stage.



RTS517 MITSUBISHI Challenger Two Cross Bar Track Mount System

11

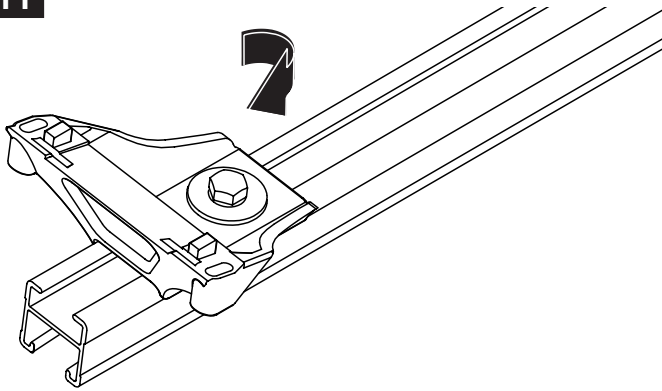

Finger tighten the leg attachment bolt so that the channel nut turns to locate across the cross bar. Leave loose enough so the cross bar can slide along the leg. The legs will require final adjustment and tightening later.

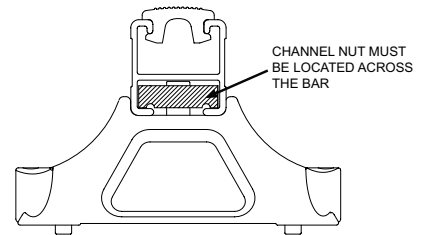

12

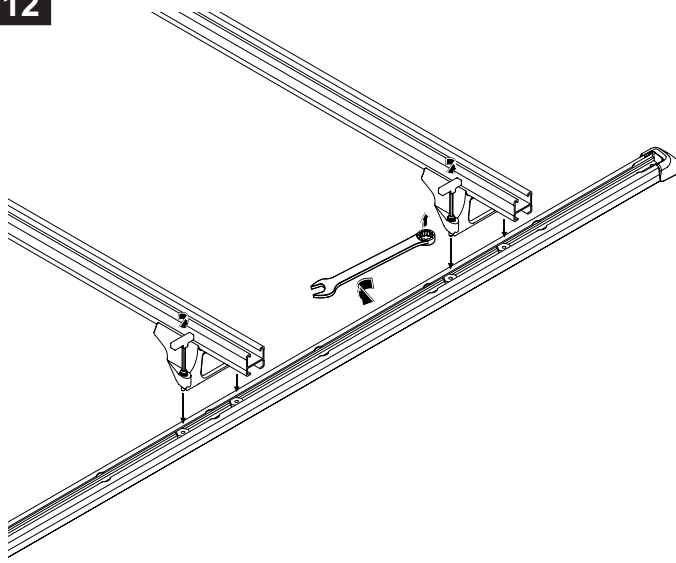

Locate the RLTP legs onto the tracks then fasten M6 security screws into the brass hex nuts. Leave loose for adjusting the legs and cross bars along the Track extrusion.

13

Once the leg and cross bar assemblies are in position use a tape measure to check the cross bar over hang is equal on both sides, re-adjust if required. Tighten the M6 security screws to **3-4N/m**. Tighten the M10 cross bar bolts to **5-6 N/m**.

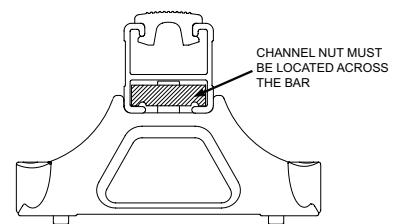
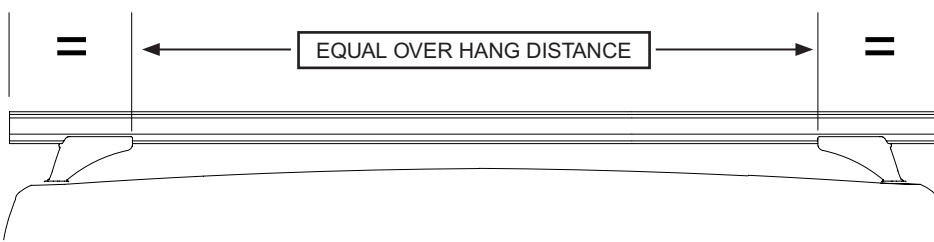

14

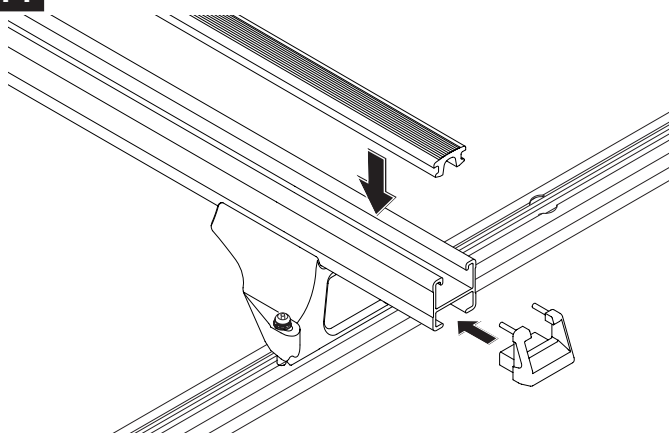

Insert the cross bar rubber buffer strip into the top of the cross bar. Insert the end caps into the ends of the cross bar, a rubber mallet may be required to fit the end caps.