

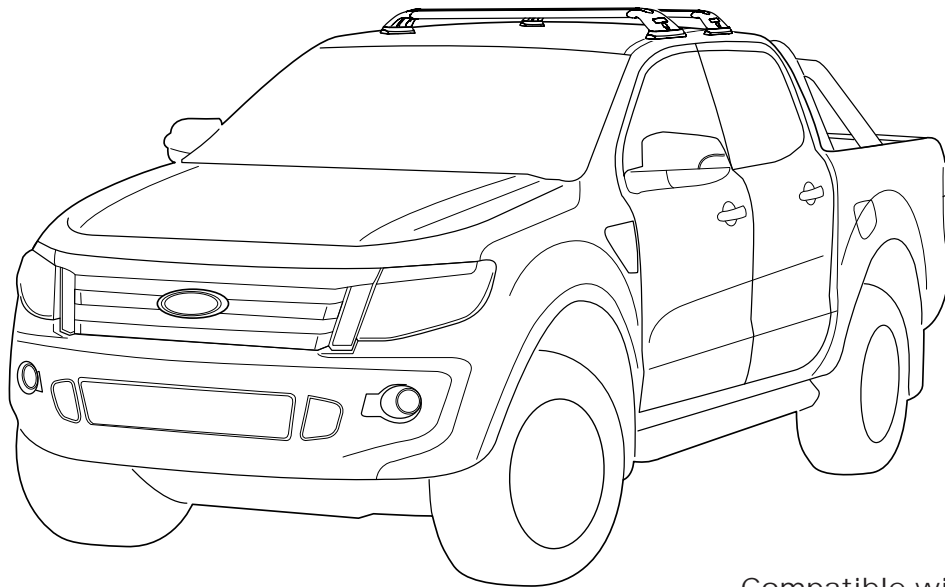

# RHINO-RACK

## RSPT525 Ford Ranger PX/ Mazda BT50 - Two Cross Bar Track Mount System

**Important:** Please read these instructions carefully prior to installation.  
Please refer to your fitting instruction to ensure that the roof racks are installed in the correct locations.  
Check the contents of kit before commencing fitment and report any discrepancies.  
Place these instructions in the vehicle's glove box after installation is complete.



Compatible with Mazda BT-50

**Care Instruction:** Wash vehicle roof prior to installing Rhino Tracks.

### Important Information

**Maximum carrying capacity: 100kg**

**Recommendations:**

It is essential that all bolt connections be checked after driving a short distance when you first install your cross bars. Bolt connections should be checked again at regular intervals (probably once a week is enough, depending on road conditions, usage, loads and distances travelled). You should also check the cross bars each time they are re-fitted.

Make sure to fasten your load securely. Please ensure that all loads are evenly distributed and that the centre of gravity is kept as low as possible.

**Use only non-stretch fastening ropes or straps.**

**Sensitivity to cross winds, behaviour in curves and braking.**

The handling characteristics of the vehicle, changes when you transport a load on the roof. For safety reasons, we recommend you exercise extreme care when transporting wind-resisting loads; special consideration must be taken into account when braking.

**Please remove cross bars when putting vehicle through an automatic car wash.**

**Load Ratings:**

Maximum permissible load is 100kg per pair of cross bars (include the weight of the cross bars, 5kg). When cross bars are to be used in off-road conditions, please build a safety factor of 1.5 into this load limit. Although the cross bars are tested and approved to AS1235-2000, Australian road conditions can be much more rigorous. However, increasing the number of cross bars does not increase the vehicles maximum permissible roof loading.

**Note for Dealers and Fitters:**

It is your responsibility to ensure instructions are given to the end user or client.

Rhino-Rack  
3 Pike Street, Rydalmere,  
NSW 2116, Australia.  
(Ph) (02) 9638 4744  
(Fax) (02) 9638 4822

Document No: R218  
Prepared By: Andy Wana  
Authorised By: Chris Murty

Issue No: 01  
Issue Date: 09/07/2012

These instructions remain the property of Rhino-Rack Australia Pty. Ltd. and may not be used or changed for any other purpose than intended.



# RSPT525 Ford Ranger PX/ Mazda BT50 - Two Cross Bar Track Mount System

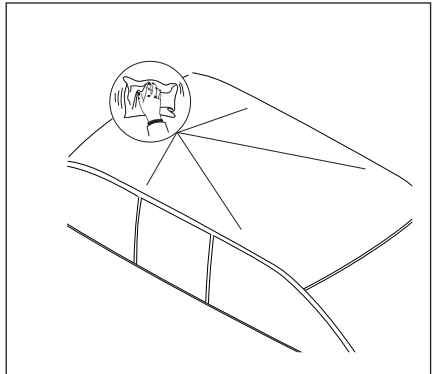
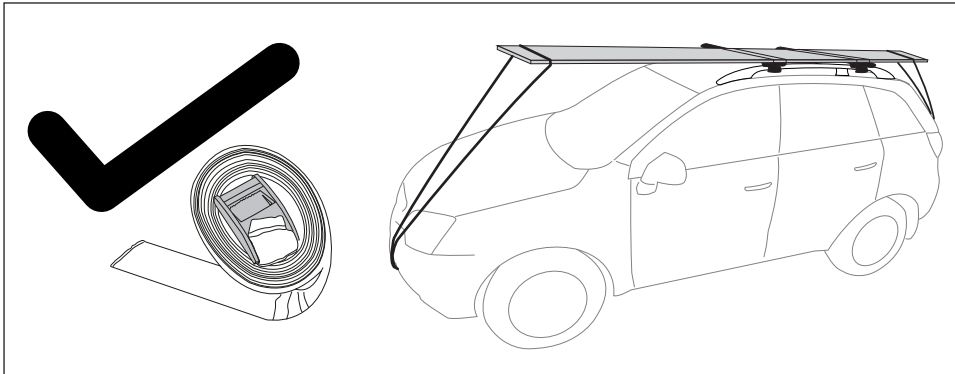
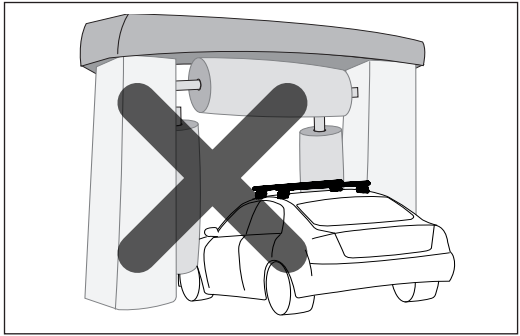
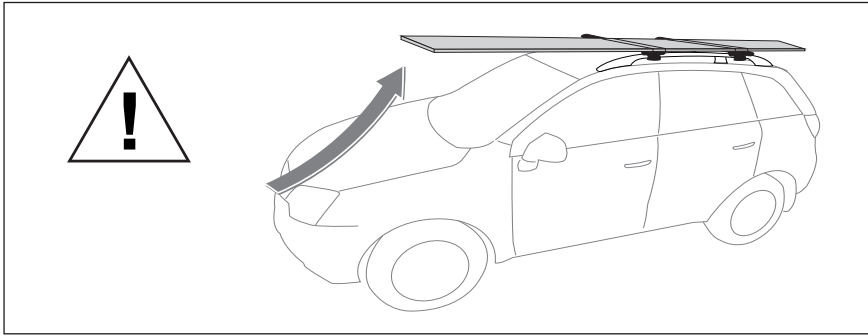

## WARNING! Important Load Carrying Instructions

With utility vehicles, the cabin and the canopy move independently. Roof racks and vehicle can be damaged if the item transported is rigidly fixed at points on both the cabin and canopy. Instead, rigidly fix to either the cabin roof racks or the canopy roof racks.

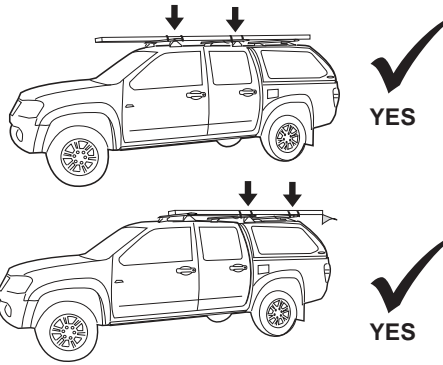
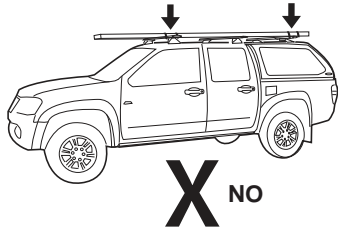

## Parts List

Item	Component Name	Qty	Part No.
1	Track (Left and Right)	2	A528
2	End Cap Left Hand Side	2	CA1127
3	End Cap Right Hand Side	2	CA1128
4	01661-00619 Avdel Rivet	16	H008
5	Sportz Rubber Strip FRONT 969mm	1	R011
6	Sportz Rubber Strip REAR 954mm	1	R011
7	Sportz Cross Bar FRONT 969mm	1	A155
8	Sportz Cross Bar REAR 954mm	1	A155
9	RSP Leg with flap	4	M561
10	Security Allen Key	1	Sec Key S
11	10G x 1/2 Pan Head Phillips Screw	4	B045
12	M6 x 40mm Security Screw	4	B085
13	M6 Spring Washer	4	W004
14	M6 x 12.5mm Flat Washer	4	W003
15	RLCP Top Pad	4	M173
16	RLCP Bottom Pad	4	M172
17	Dowel Nut Housing	4	A341
18	M6 x 16mm Dowel Nut	4	N027
19	Fitting Instruction	1	R218

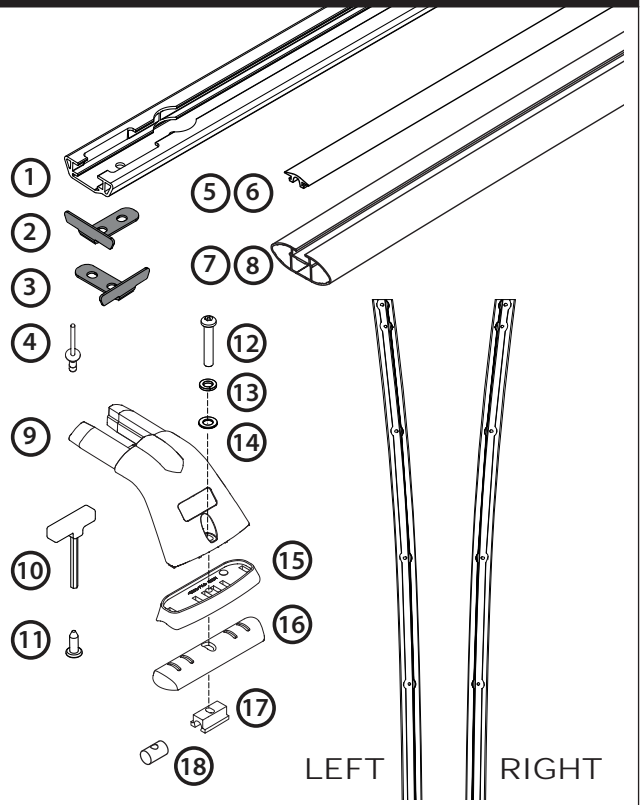



# RSPT525 Ford Ranger PX/ Mazda BT50 - Two Cross Bar Track Mount System

## Tools Required:

- |                          |  |
|--------------------------|--|
| Pneumatic or Concertina  | 5mm drill bit.                           |
| Rivet gun.               | Vacuum cleaner.                          |
| Masking tape.            | Cold galvanizing solution & small brush. |
| Rubber Mallet.           | Selleys Butyl Mastic.                    |
| Power or Cordless drill. |  |

## SPECIAL NOTE:

Assistance by a second person is required to maintain accurate alignment of the Track extrusion while holes are marked out and drilled.

## IMPORTANT Care Instruction:

Wash the roof prior to fitting the track mount system, especially the area the track will be mounting to. PLEASE READ THROUGH INSTRUCTIONS BEFORE FITTING.

**1**

**LEFT Track**

**RIGHT Track**

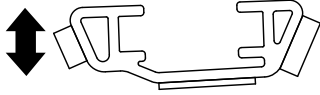

Short edge faces  
OUTSIDE of vehicle.

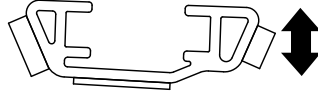

Short edge faces  
OUTSIDE of vehicle.

The track extrusions are Left and Right handed. Each track has 2 circular cut outs at one end, this denotes the **FRONT** of the vehicle. The single large rectangular cut out denotes the **REAR**.

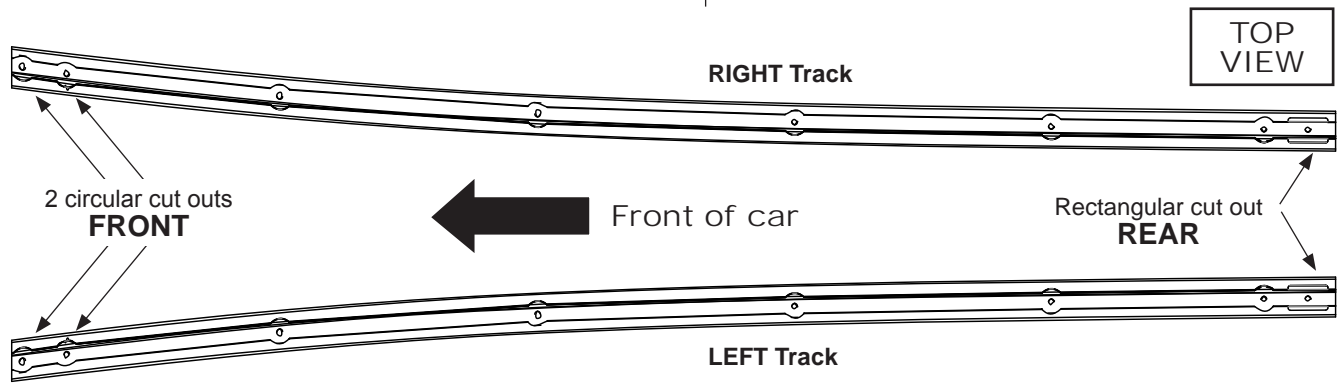

**NOTE: WE RECOMMEND THAT YOU COMPLETELY INSTALL ONE TRACK AT A TIME.**

**2**

Align the **REAR** of the track as shown. It should sit between the gap of the 2 doors.

REAR of car

Visible line on the roof moulding

Approximately 185mm from the REAR of car

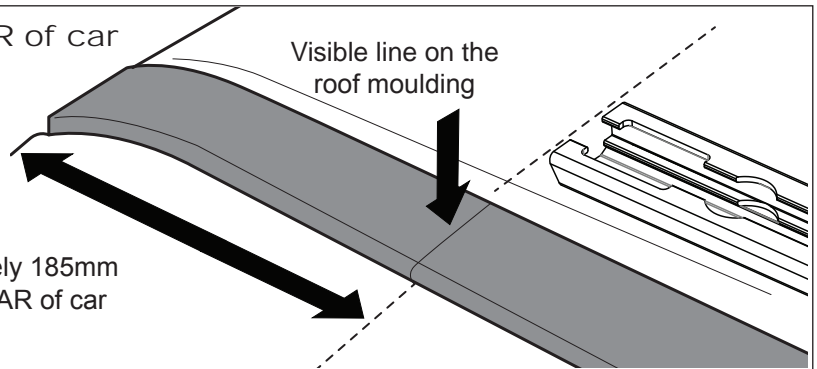

**3**

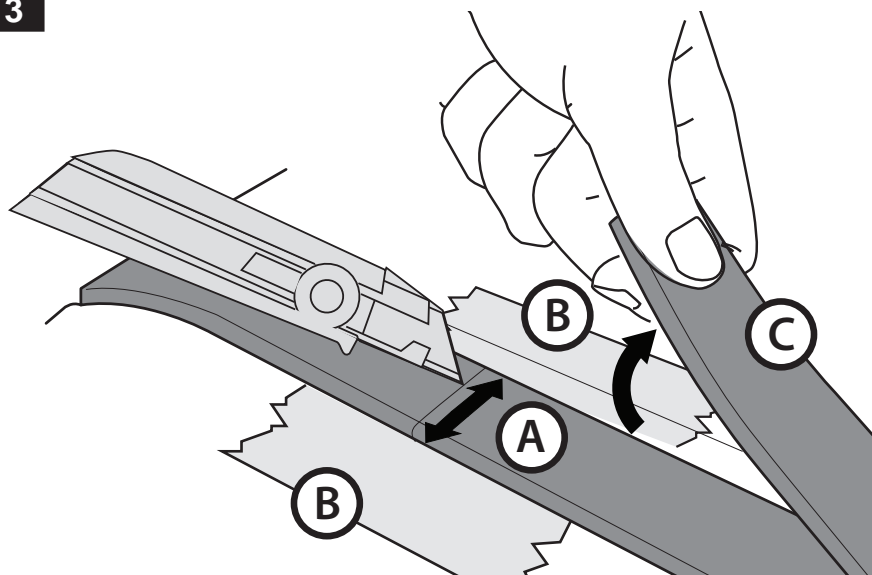

A. Knife cut the rear section of the trim exactly on the line in the moulding location. The line is approximately 185mm from the back edge of the moulding.

B. Make sure you apply protection on both sides of the track to prevent the knife from slipping and marking the roof.

C. Use fingers to slowly peel back the rear edge of the trim until the double sided tape lets go.



# RSPT525 Ford Ranger PX/ Mazda BT50 - Two Cross Bar Track Mount System

**3**

Mark the front edge of moulding by placing the track against it. Allow an **additional 4mm** for the end caps. Place a cut line on the front trim area. Continue to peel from the back (step 2) till trim and double tape is off the vehicle. **Any excess double sided tape left on the vehicle must be completely cleaned off for track fitment**

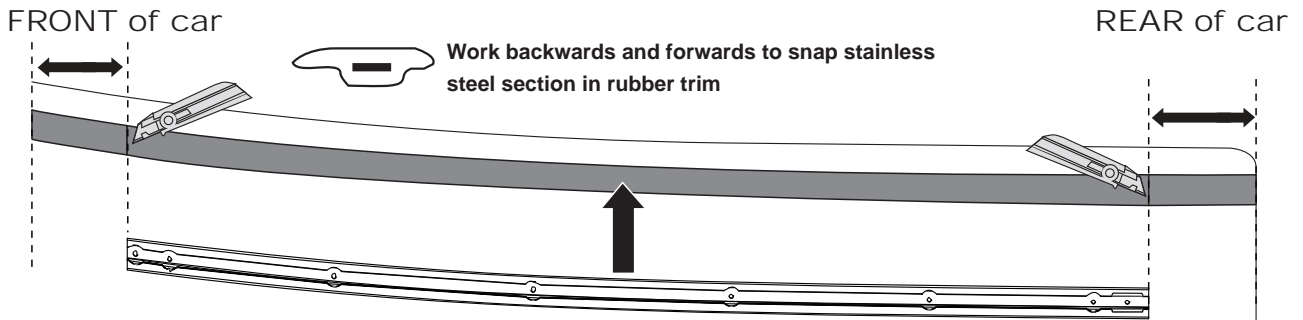

**4**

**NOTE:** (P1) refers to the person spot drilling.  
(P2) refers to the person assisting.

- A. Maintain downward pressure on the track while spot drilling all holes.
- B. Person one (P1), with the assistance of a second person (P2). Hold the track firmly in position. Spot drill the first 4 holes. P2 to hold the track and maintain alignment of the 5th hole as P1 moves around towards the rear of the track. P2 and P1 hold the track while maintaining 5th hole alignment and P1 to continue spot drilling holes 5 - 8

Right **FRONT**  
2mm spacing  
from end of trim

Right **REAR**  
2mm spacing  
from end of trim

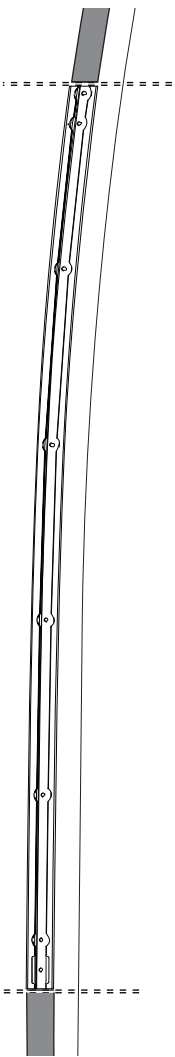

Maintain downwards pressure on track.

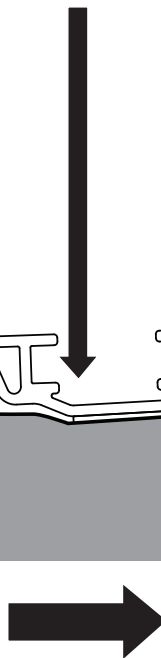

**OUTSIDE** of vehicle.

Use masking tape around door and window seals to prevent drill swarf entering these areas.

Hole 8.

Hole 1.

Right **REAR**

Spot drill the 8 track holes starting from the Rear.

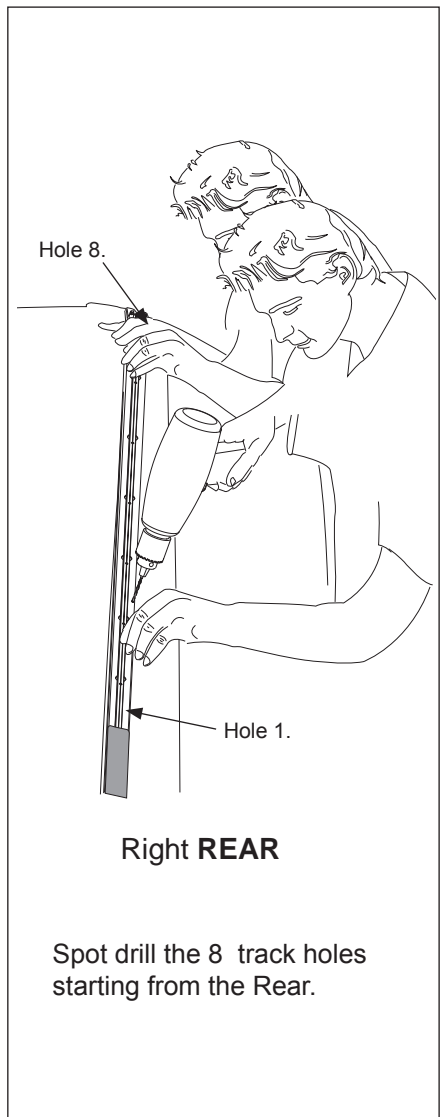



# RSPT525 Ford Ranger PX/ Mazda BT50 - Two Cross Bar Track Mount System

5



All 8 holes can now be drilled through. A drill stop must be used to prevent drilling through the hood lining on the inside. **Make sure that when drilling you hold the drill perpendicular to the roof angle.** The roof skin is approx. 2-3mm thick.

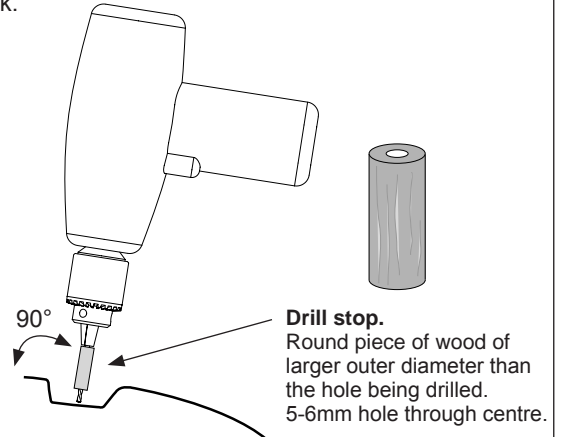

**Drill stop.**  
Round piece of wood of larger outer diameter than the hole being drilled. 5-6mm hole through centre.

6

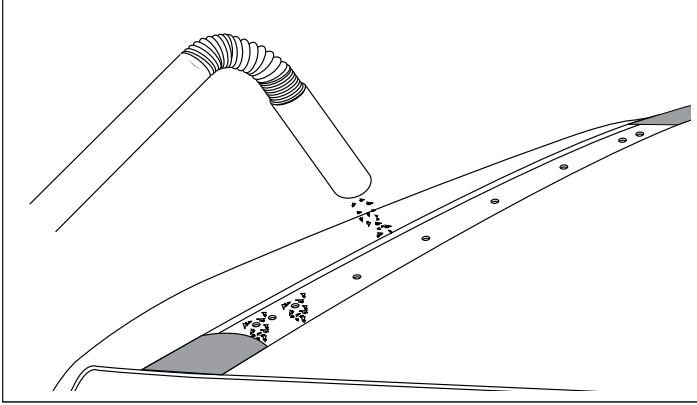

Use a vacuum to remove swarf to eliminate scratching. Wipe clean the installation area of the roof.



**ALWAYS vacuum swarf.**  
**NEVER blow swarf away with an air gun as it will cause rust**

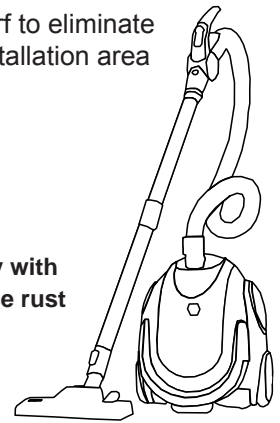

7

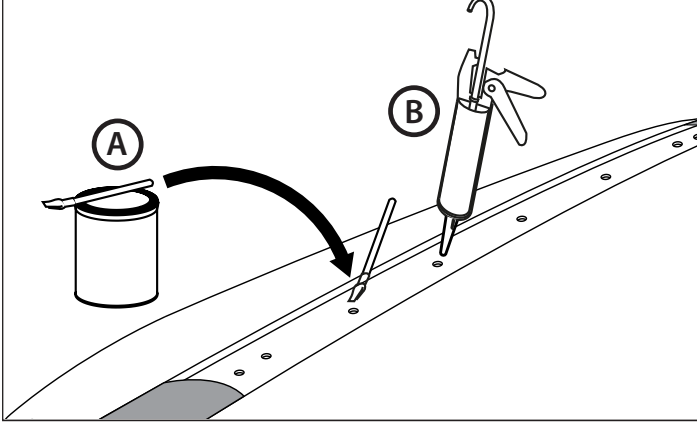

A. Apply a liberal amount of cold galvanizing solution to the inside and surrounds of all holes. Allow cold galvanizing solution to dry as per instructions (5-10 mins in hot, dry weather. Longer in cold, wet weather)

B. Apply a liberal amount of Selleys Butyl Mastic in and around each hole. This is an important step for waterproofing the roof area.

8

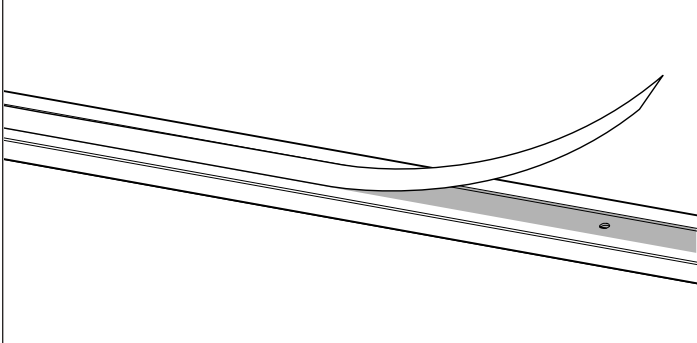

Peel the white backing strip off the track foam tape.



# RSPT525 Ford Ranger PX/ Mazda BT50 - Two Cross Bar Track Mount System

**9**

Insert the end caps at each end. Ensure that the profile of the end cap matches the ends as shown

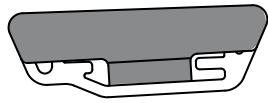

Align End Caps to Track Profile

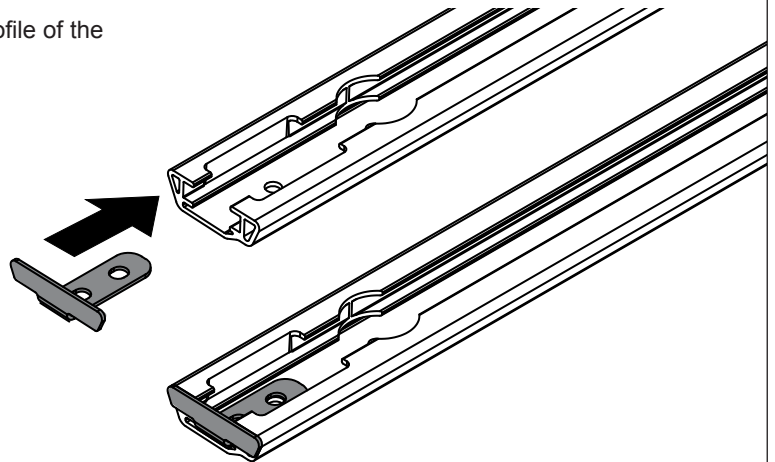
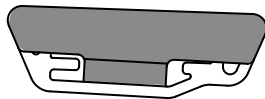

**10**

Line up and place all 8 rivets in their respective holes. Pay extra attention to the 5th hole (from the front) where the air bag module resides. With the assistance of a second person to maintain track alignment start riveting from the centre rivet. Follow the numerical riveting order as shown below. Holes 6 and 8 will have the end caps.

FRONT of car

End cap.

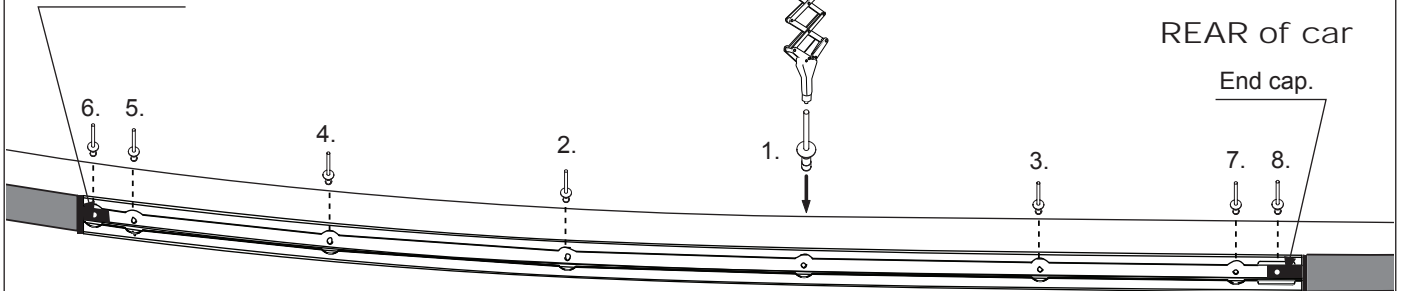

REAR of car

End cap.

**11**

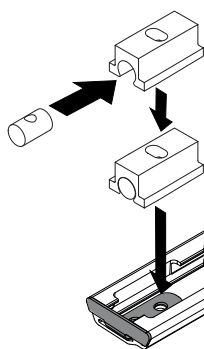

Locate dowel nut into aluminium housing. Slide into track. Slide to the position shown below.

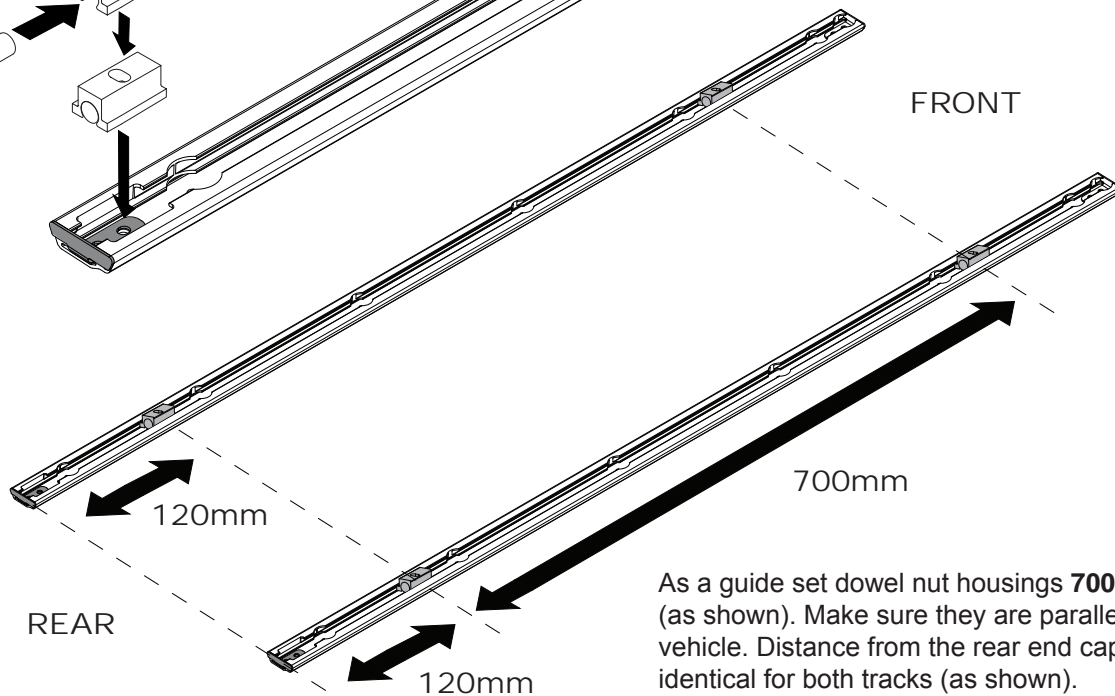

As a guide set dowel nut housings **700mm** apart (as shown). Make sure they are parallel across the vehicle. Distance from the rear end cap should be identical for both tracks (as shown).



## RSPT525 Ford Ranger PX/ Mazda BT50 - Two Cross Bar Track Mount System

12

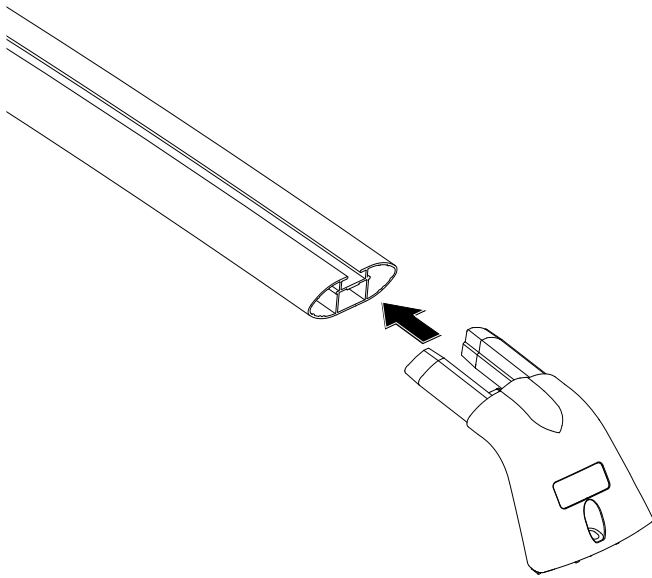

### Attach sportz legs to cross bars:

Insert the sportz leg fully into the cross bars. A rubber mallet may be required to knock the leg in place.

13

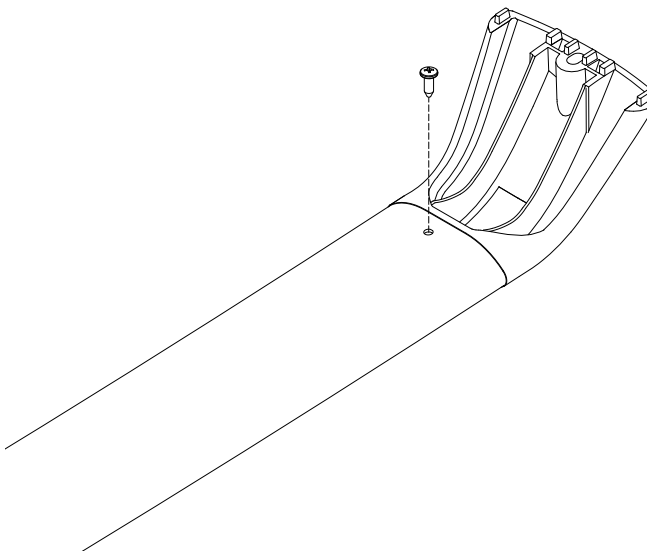

### Attach phillips head screw:

From the underside of the cross bar insert the phillips head screw to secure each cross bar to the legs.

14

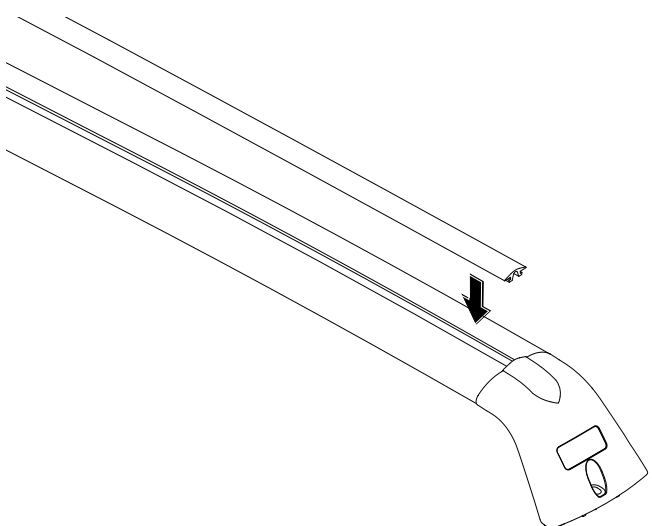

### Insert cross bar rubber.

Insert the correct length cross bar rubber into the top of the corresponding cross bar. The rubber may need to be trimmed level with end of the cross bar. Do not stretch the rubber.

**Front = 969mm.**

**Rear = 954mm.**



# RSPT525 Ford Ranger PX/ Mazda BT50 - Two Cross Bar Track Mount System

15

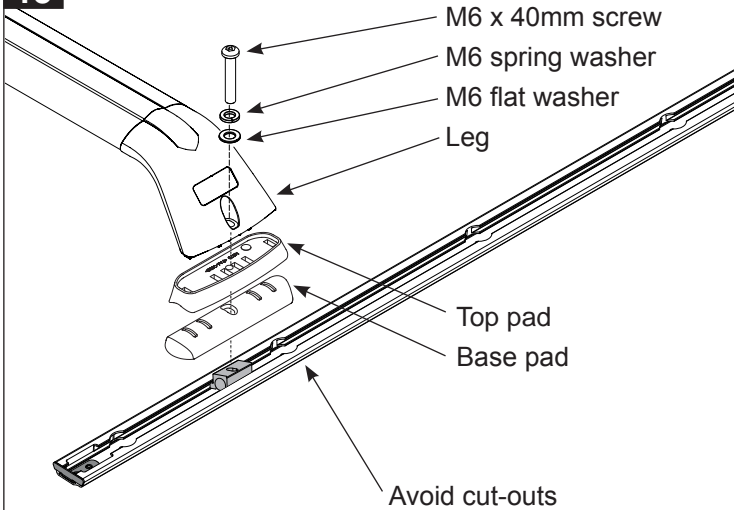

Attach the legs to track using supplied screws and washers. Finger tighten only.

Make sure to that aluminium dowel nut housing is not placed under cut-out holes in the track.

16

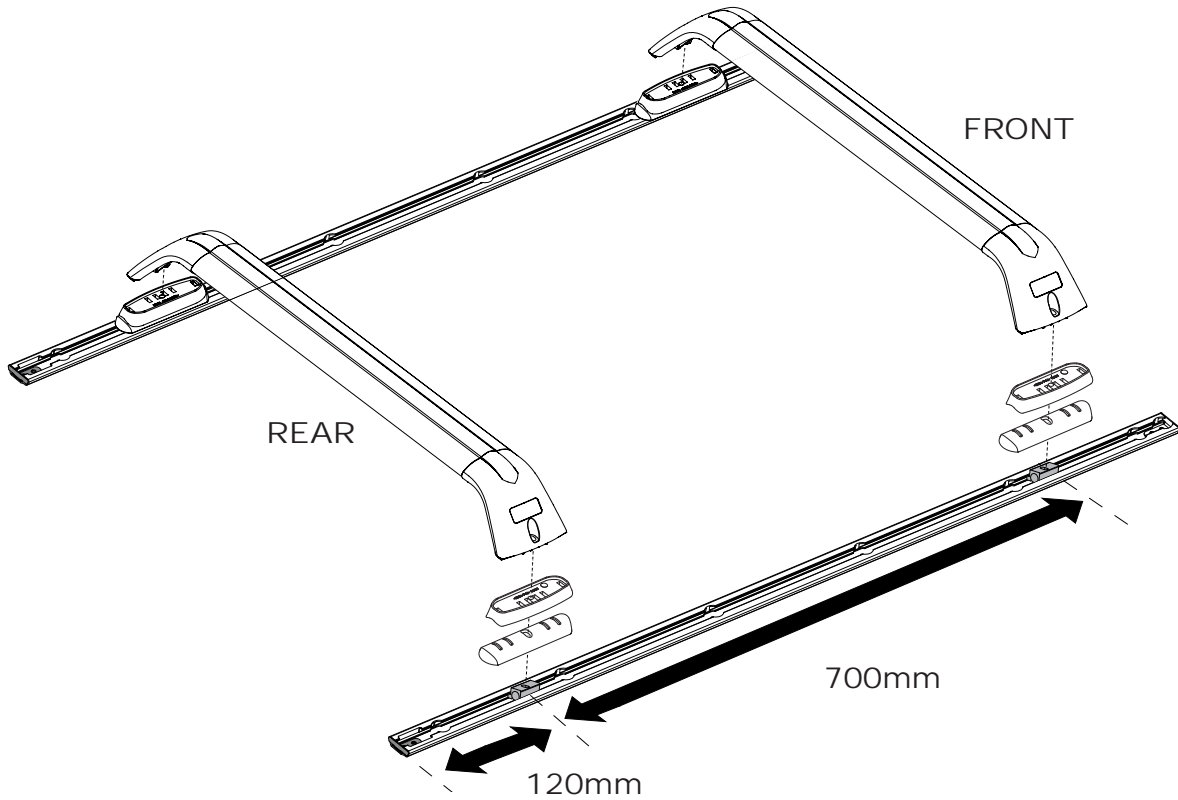

17

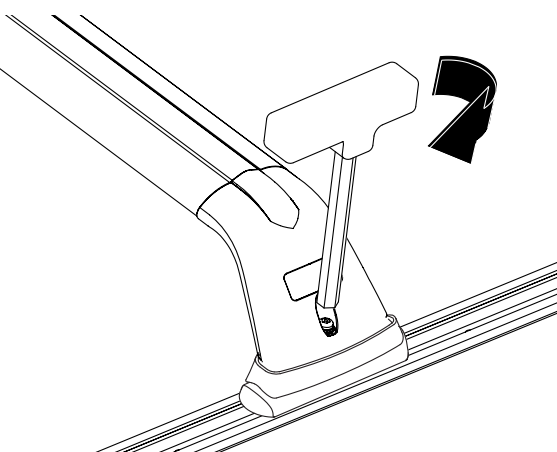

**Tighten M6 screws.**

Progressively and evenly tighten both the left and right side M6 leg screws to secure.

**Tighten the M6 screws to 3-4 Nm.  
Do not over tighten.**





## 18 Accessory flap.

1. Remove crossbar rubber.

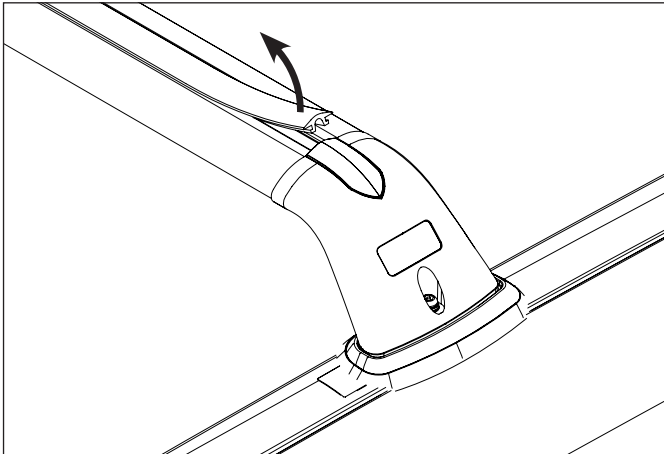

2. Lift flap.

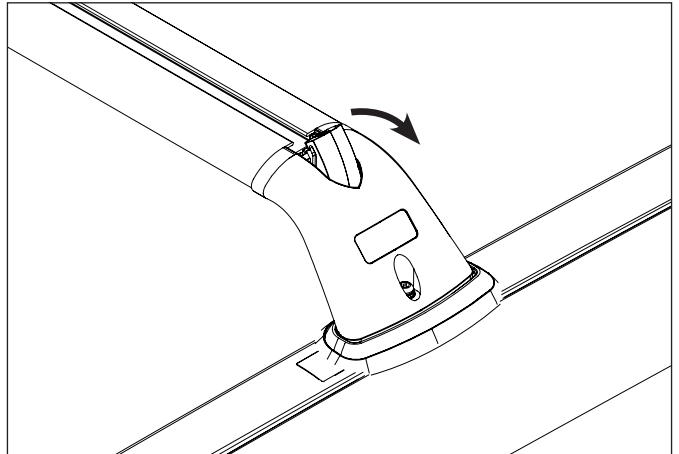

3. Push flap down to allow hardware to slide into C channel.

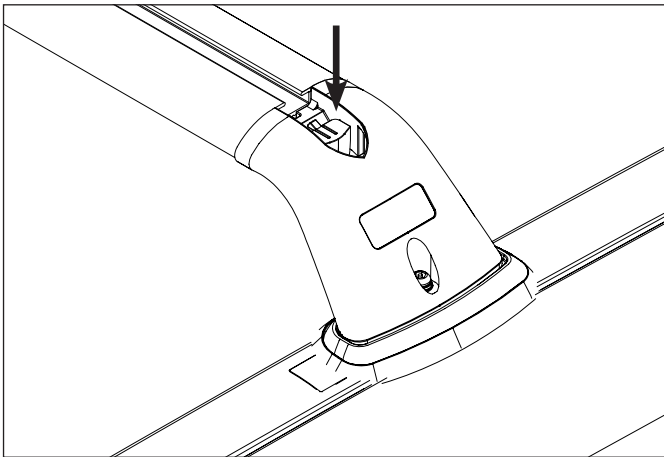

4. Re-fit flap using security Allen key.

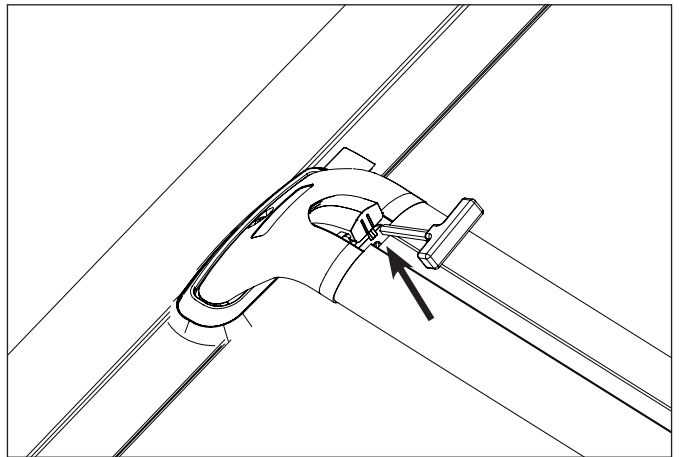

## 19

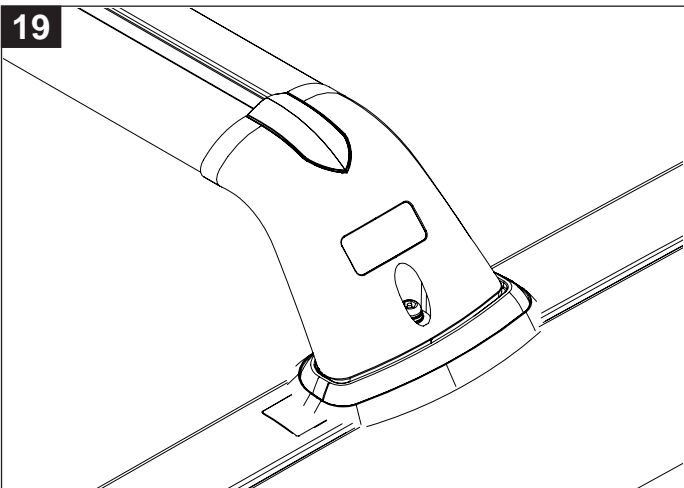

## 20

Pad cover plates are provided for when crossbars are removed.

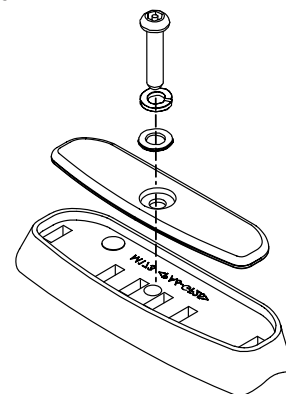

### WARRANTY INFORMATION

Rhino-Rack warrants your new product against any manufacturing faults for the period specified on our website, provided the terms and conditions of the warranty are met. Some exclusions apply. To qualify for warranty cover, you must fill out the online warranty registration form. You should ensure that you retain your original proof of purchase, which will be required for any warranty claim.

For all warranty terms and conditions, please visit the Rhino Rack website for details

[www.rhinorack.com/warranty](http://www.rhinorack.com/warranty)