



RHINO-RACK

Aerodynamic & Heavy Duty Roof Rack Systems

RTS521 Holden Colorado RC Space Cab - Rhino Track Mount. Holden Rodeo RA Space Cab - Rhino Track Mount.

Important: Please read these instructions carefully prior to installation.
Please refer to your fitting instruction to ensure that the cross bars are installed in the correct locations.
Check the contents of kit before commencing fitment and report any discrepancies.
Place these instructions in the vehicle's glove box after installation is complete.

Maximum carrying capacity: 50kg.

Layout

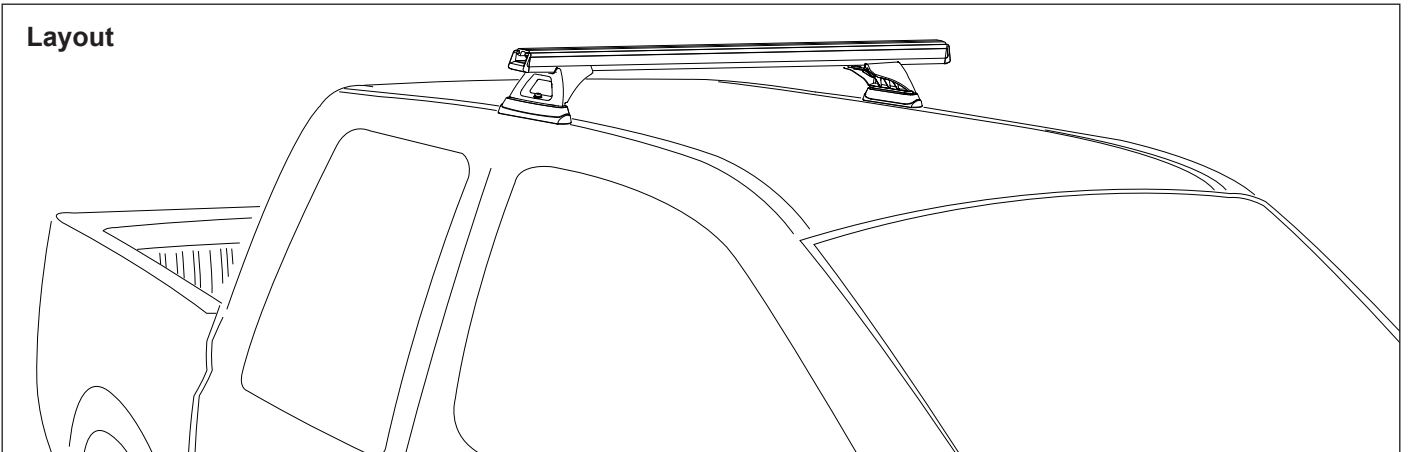

Care Instruction: Wash and clean vehicle roof prior to fitting the tracks and cross bar.

Important Information

Maximum carrying capacity: 50kg.

Recommendations:

It is essential that all bolt connections be checked after driving a short distance when you first install your cross bars. Bolt connections should be checked again at regular intervals (probably once a week is enough, depending on road conditions, usage, loads and distances travelled). You should also check the cross bars each time they are re-fitted.

Make sure to fasten your load securely. Please ensure that all loads are evenly distributed and that the centre of gravity is kept as low as possible.

Use only non-stretch fastening ropes or straps.

Sensitivity to cross winds, behaviour in curves and braking.

The handling characteristics of the vehicle, changes when you transport a load on the roof. For safety reasons, we recommend you exercise extreme care when transporting wind-resisting loads; special consideration must be taken into account when braking.

Please remove cross bars when putting vehicle through an automatic car wash.

Load Ratings:

Maximum permissible load is 50kg per cross bar (include the weight of the cross bar, 5kg). When cross bars are to be used in off-road conditions, please build a safety factor of 1.5 into this load limit. 34kg for off-road use. Although the cross bars are tested and approved to AS1235-2000, Australian road conditions can be much more rigorous. However, increasing the number of cross bars does not increase the vehicles maximum permissible roof loading.

Note for Dealers and Fitters:

It is your responsibility to ensure instructions are given to the end user or client.

Rhino-Rack
3 Pike Street, Rydalmere,
NSW 2116, Australia.
(Ph) (02) 9638 4744
(Fax) (02) 9638 4822

Document No: RR-190
Prepared By: Craig Jones
Authorised By: Gary England

Issue No: 01
Issue Date: 17/09/2008

These instructions remain the property of Rhino-Rack Australia Pty. Ltd. and may not be used or changed for any other purpose than intended.



Parts List

Maximum carrying capacity: 50kg.

Item	Component Name	Qty.	Part No.
1	Track End Tab	4	C351
2	Track Extrusion LEFT 500mm	1	A329
3	Track Extrusion RIGHT 500mm	1	A329
4	Heavy Duty Buffer Strip 1250mm	1	R003
5	Heavy Duty Cross Bar End Cap	2	M002
6	Heavy Duty Cross Bar 1250mm	1	A019
7	M6 x 40mm Security Screw	2	B085
8	M6 Spring Washer	2	W004
9	M6 x 12.5mm Flat Washer	2	W003
10	RLCP Leg	2	M123
11	RLCP Top Pad	2	M173
12	RLCP Bottom Pad	2	M172
13	M6 Brass Hex Nut	2	N036
14	M10 x 20mm Hex Bolt	2	B003
15	M10 Shakeproof Washer	2	W021
16	M10 x 38mm Flat Washer	2	W022
17	M10 Channel Nut	2	N024
18	5mm Rivet	8	H008
19	Security Allen Key	1	H021
20	Fitting Instruction	1	RR190

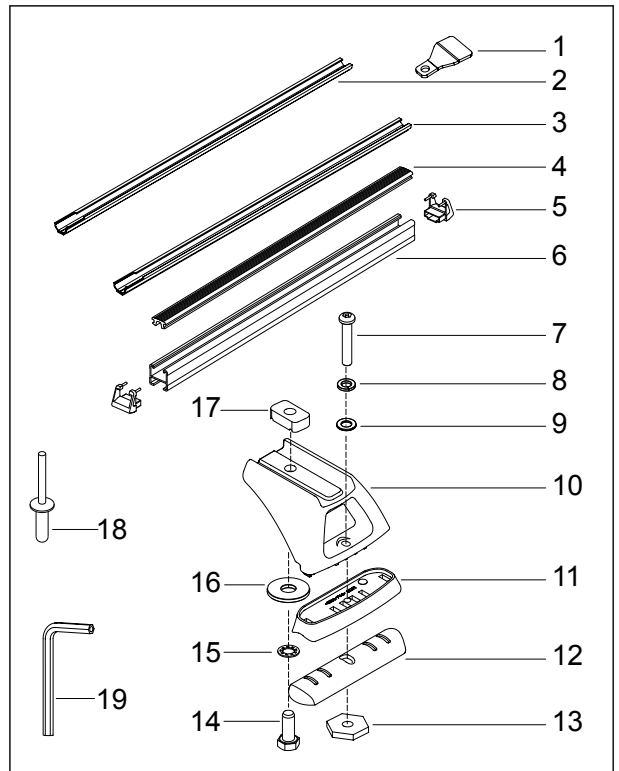

Tools Required:

- | | |
|------------------------------------|--|
| Pneumatic or concertina rivet gun. | Side cutters or Tin snips. |
| Marking pen/pencil. | Selleys Butyl Mastic. |
| Power or Battery Drill. | Caulking Gun. |
| 3 & 5mm drill bit & depth stop. | 5mm Security Allen key, provided in kit. |
| Vacuum cleaner. | Measuring tape. |
| Cold galvanizing solution & brush. | Flat Head screwdriver. |
| Knife (<i>stanley type</i>). | 16mm Spanner. |
| | Plastic Scraper. |



Drill depth stop.

Round piece of wood or plastic of larger outer diameter than the hole being drilled. 5-6 mm hole through centre.

1 Drill through roof trim.

Measure a distance of 130mm from the defined line on the roof trim at the front (*its about 20mm back from the wind-screen rubber*). Drill three holes of diameter 3mm through the trim, it has a steel backing. Measure a further 505mm from these holes, drill three more holes. **DO NOT DRILL INTO THE ROOF.**

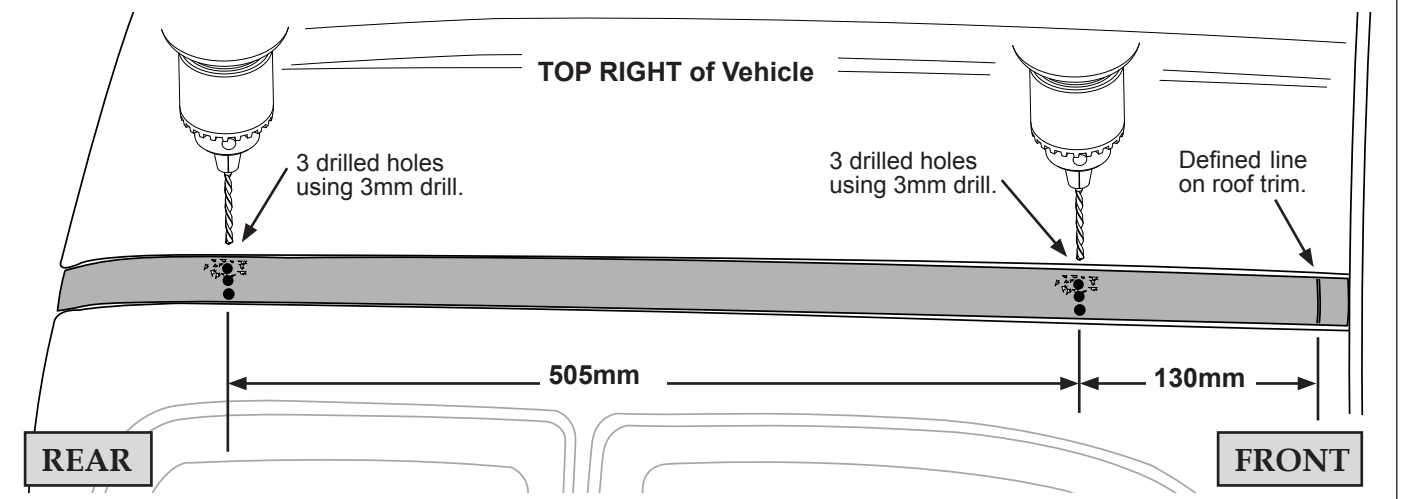



2 Break and remove trim.

a. Stretch and bend the roof trim up in the middle. Slide a blunt instrument under the trim to support it. Cut with side cutters or tin snips. b. Support the roof trim at the drilled holes. Bend the trim back and forth to break at the drilled holes.

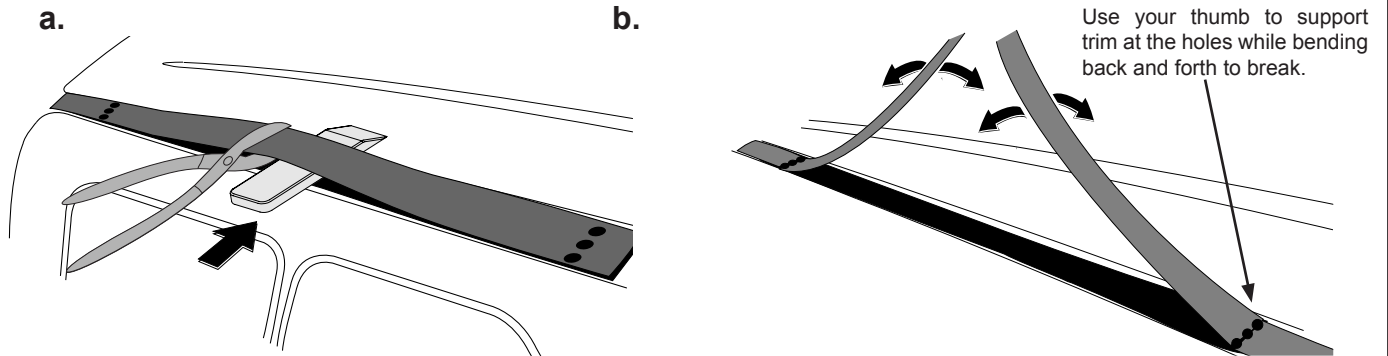

3 Remove rubber strip.

a. Use a knife to cut the rubber strip level with the edges of the remaining roof trim. Pull rubber strip out of the roof channel. b. **The grey sticky foam left behind must be fully scraped off before the tracks can be installed.** Use a plastic scraper and non petroleum solvent such as Cleansol to help remove. The roof channel must be totally clean before proceeding any further.

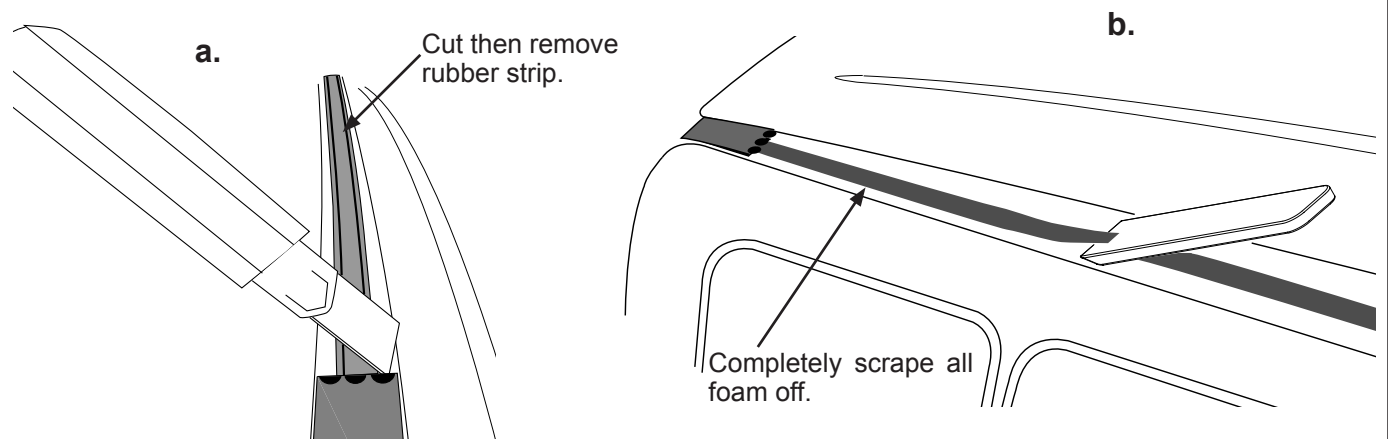

4 Tracks.

Track extrusions are **LEFT** (passenger side) and **RIGHT** (driver side) handed.

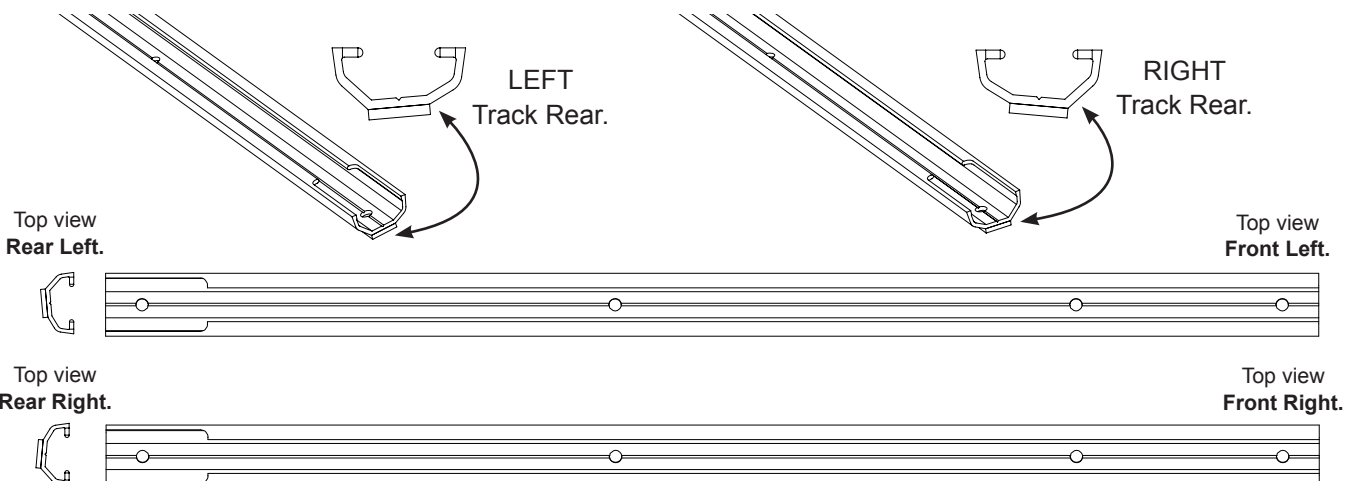



5 Correctly position track.

Locate track in roof channel. Screw an M6 brass hex nut and M6 screw together. Slide screw and brass hex nut in from slot at rear of track. Slide along track extrusion to check the angle. Look end on to make sure the track is sitting properly in the roof channel. The screw should be close to vertical when the track is in the correct position.

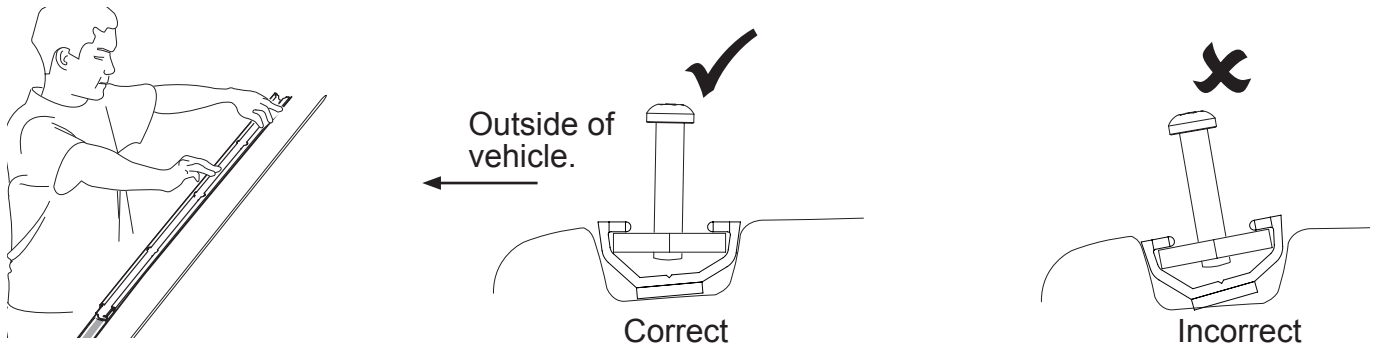

6

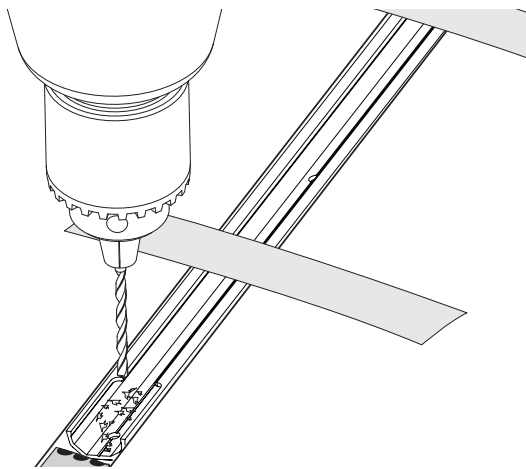

Spot drill for holes.

Hold the track in place while the holes are marked out. Masking tape can be used to hold track. Use a 5mm drill bit to spot drill through each of the holes in the track. Start at the rear and work forward while maintaining spot drill mark alignment.

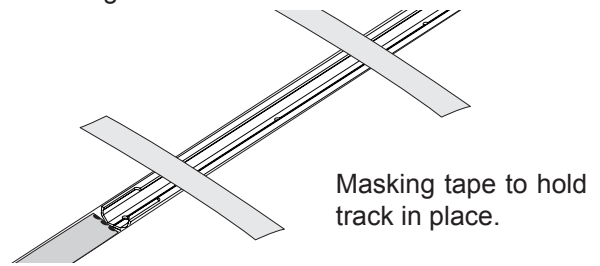

7

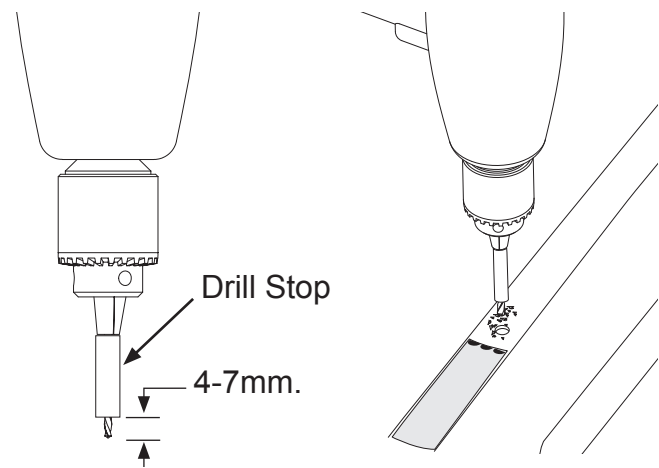

Drill through.

Remove the track. Marked holes can now be drilled through the roof skin using a 5mm drill bit. **A DRILL STOP MUST BE USED** to avoid penetrating the inside hood lining.

8

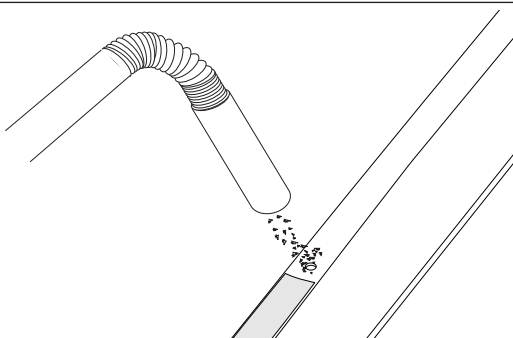

Vacuum swarf.

Swarf must be vacuumed from roof to avoid rust spots and scratching. Carefully wipe with a clean rag to remove any excess.

DO NOT USE AN AIR GUN to blow swarf as it will get trapped under the remaining roof trim.



9

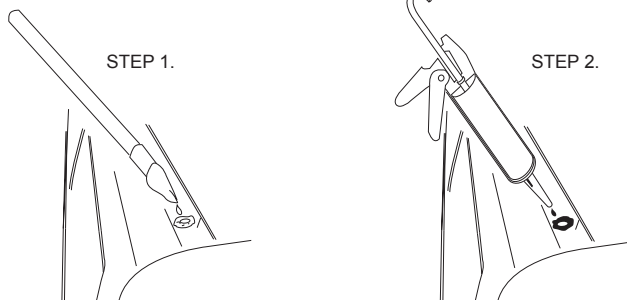

Rust preventative and sealer.

Apply cold galvanizing solution to the inside and surrounds of all holes. Allow to dry, about 10 minutes, then apply a liberal amount of Selleys Butyl Mastic in and around each hole.

10

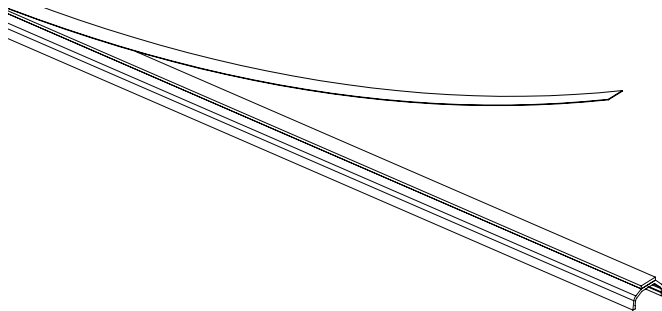

Backing tape.

Completely remove white backing tape from each track extrusion.

11 Fasten Track.

Accurately place the track over the drilled holes in the roof channel using the rivets to position. **Make sure track orientation is correct, (refer to step 4).** Place the metal track end tabs at the end of each track. Secure end tab with rivet. Using either a pneumatic or concertina type rivet gun, rivet the track into place. Push down with pressure while popping rivets to make sure they are all firmly seated onto the base of the track.

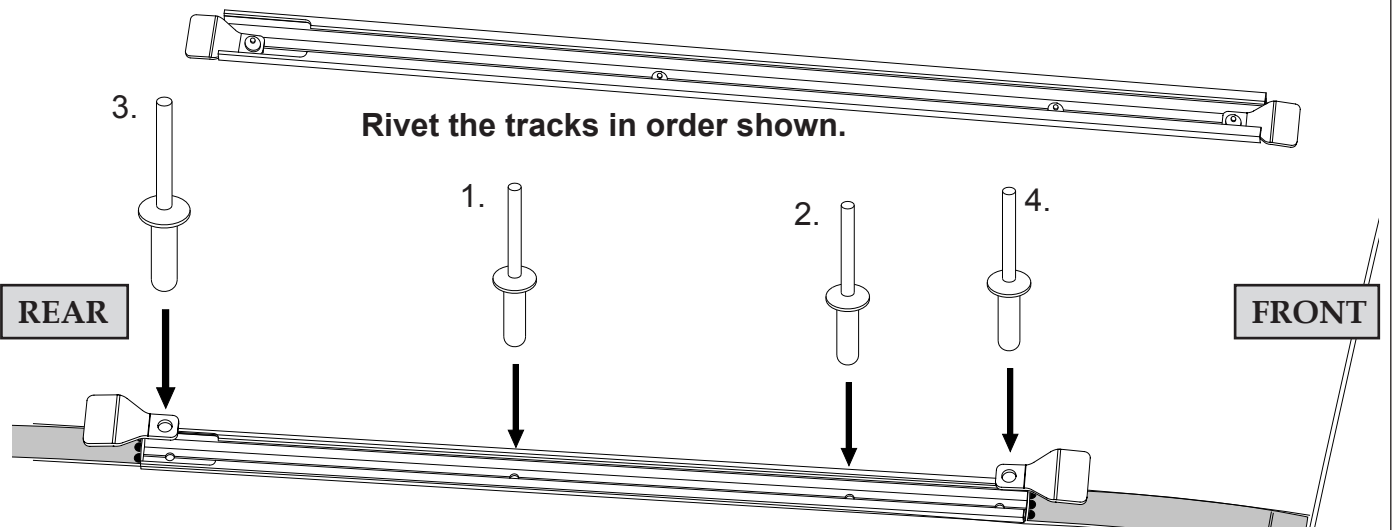

12

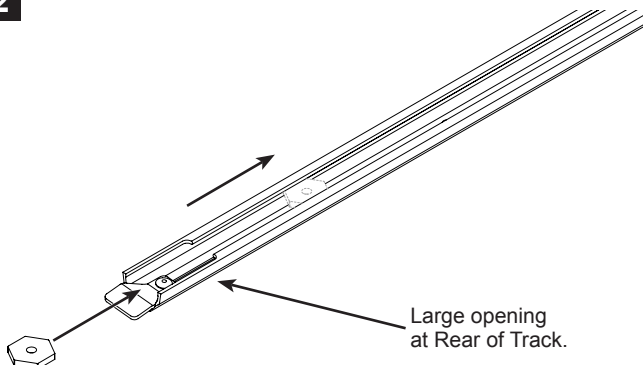

Brass hex nuts.

Insert one brass hex nut per track. Slide brass nut to desired position using the large slot at rear of track.



13

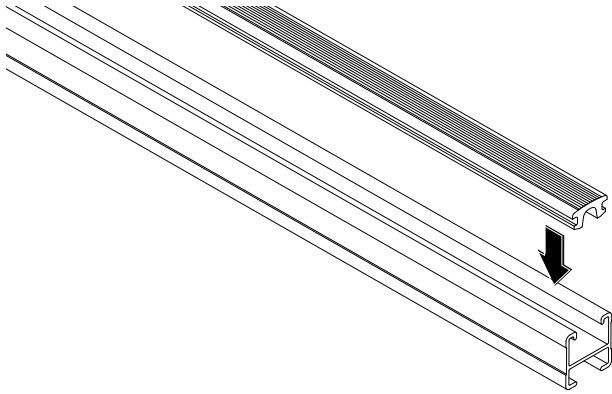

Insert cross bar rubber.

Insert the cross bar rubber into the top of the cross bar. The rubber may need to be trimmed level with end of the cross bar.

14 Legs & cross bars.

Place each leg assembly over the brass hex nut in the track. Insert the M6 security screw and washers through the hole in the leg as shown and screw into the brass hex nut. Make sure the legs are parallel with the opposing side.

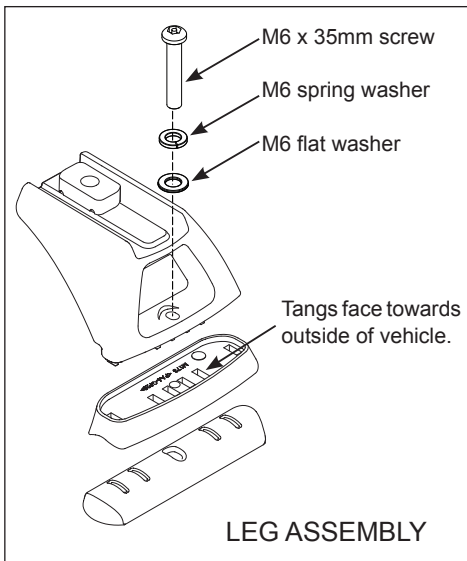

Do not place hex nut under cut out in rear of track.

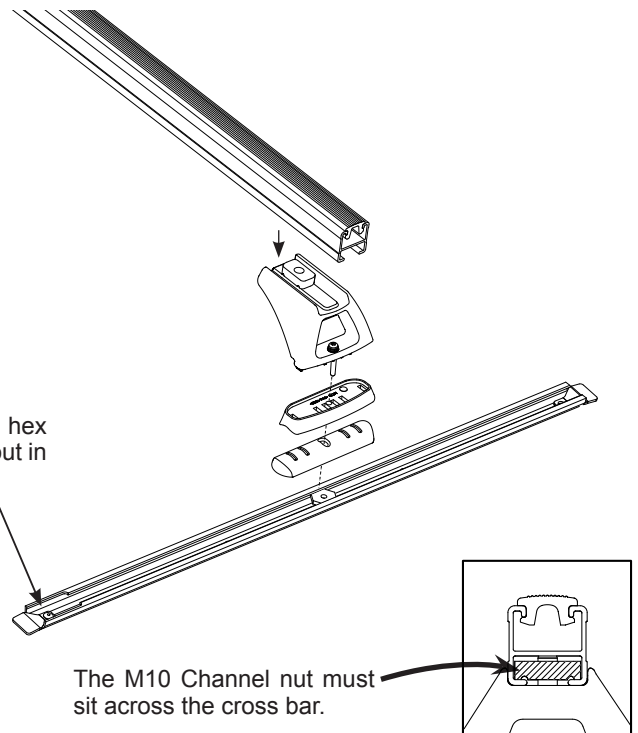

The M10 Channel nut must sit across the cross bar.

15

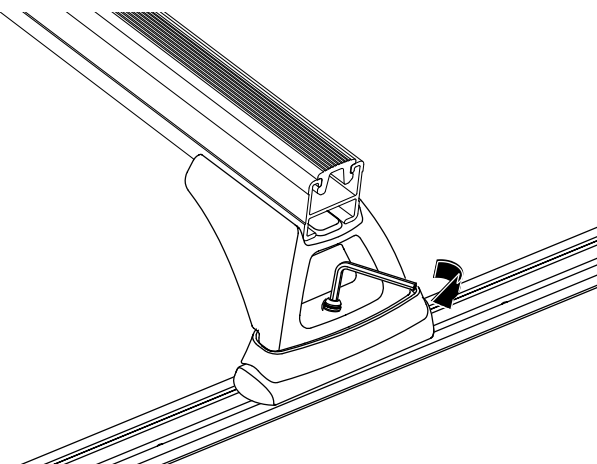

Tighten M6 screws.

Slide the cross bar to give better access to M6 screw. Progressively and evenly tighten both the left and right side M6 leg screw to secure the leg and pads to the track.

Tighten the M6 screws to 3-4 Nm.

Do not over tighten.



16 Equal overhang.

Measure to make sure the cross bar overhang is equal on both sides.

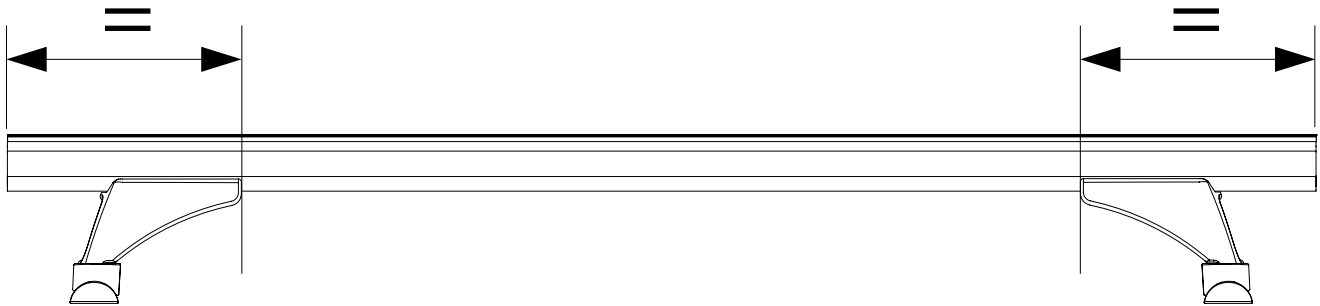

17

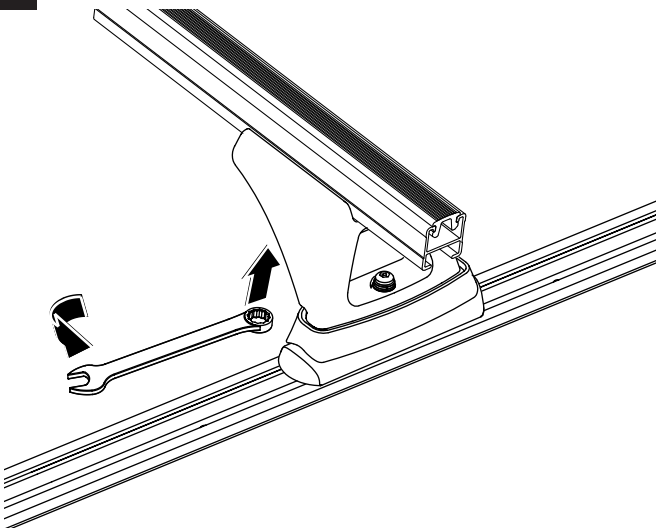

Tighten M10 bolts.

Check that both channel nuts are fully located across the cross bar before and after tightening.

Tighten the M10 cross bar attachment bolts using a 16mm spanner.

Tighten to 4-5 Nm. Do not over tighten.

The M10 Channel nut must sit across the cross bar when tight as shown.

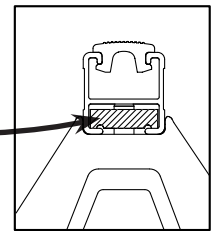

18

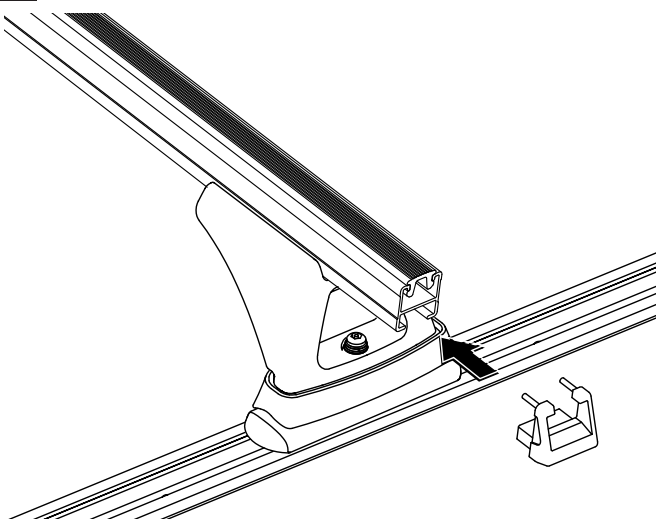

Fit end caps.

Insert an end cap into each end of the cross bar. A rubber mallet may be needed to knock them in.

Check all attachment bolts and screws after fitment.