



RHINO-RACK

RTS518 - Rhino Heavy Duty 2 & 3 Crossbar System Hyundai iLoad, iMax, i800, H-1.

NOTE:

Please read these instructions carefully prior to installation.
Check the contents of kit before commencing fitment and report any discrepancies.
Place these instructions in the vehicle's glove box after installation is complete.

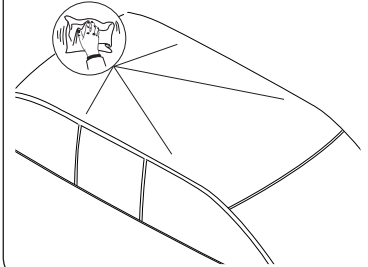
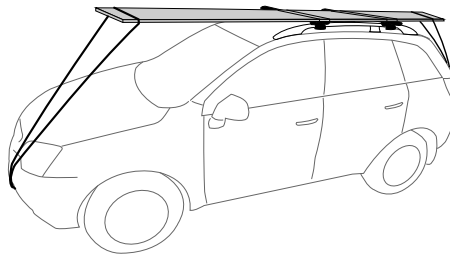
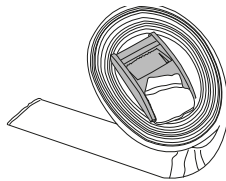
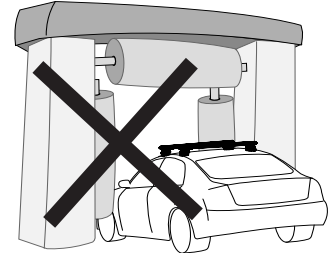
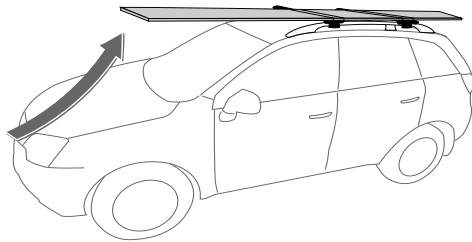

IMPORTANT: Wash vehicle roof especially the roof strip channel prior to installation.

Maximum carrying capacity: 100kg two crossbars. 125kg three crossbars.

Recommendations:

It is essential that all bolt connections be checked after driving a short distance when you first install your crossbars. Bolt connections should be checked again at regular intervals (probably once a week is enough, depending on road conditions, usage, loads and distances travelled). You should also check the crossbars each time they are re-fitted.

Make sure to fasten your load securely. Please ensure that all loads are evenly distributed over the crossbars and that the centre of gravity is kept as low as possible.

Use only non-stretch fastening ropes or straps.

Caution:

The handling characteristics of the vehicle change when you transport a load on the roof. For safety reasons, we recommend exercising extreme care when transporting large wind-resisting loads; special consideration must be taken into account when negotiating corners and under braking.

Please remove crossbars when putting vehicle through an automatic car wash.

Load Ratings:

Maximum permissible load is **100kg evenly distributed over two crossbars and 125kg evenly distributed over three crossbars**. When crossbars are to be used in off-road conditions, please build a safety factor of 1.5 into this load limit, two crossbars **67kg** and three crossbars **84kg**. Although the crossbars are tested and approved to AS1235-2000, off-road conditions can be much more rigorous. However, increasing the number of crossbars does not increase the vehicles maximum permissible roof loading.

Note for Dealers and Fitters:

It is your responsibility to ensure instructions are given to the end user or client.

Rhino-Rack
3 Pike Street, Rydalmere,
NSW 2116, Australia.
(Ph) (02) 9638 4744
(Fax) (02) 9638 4822

Document No: RR-179
Prepared By: Craig Jones
Authorised By: Chris Murty

Fit Time: 45min
Issue No: 07
Issue Date: 01/02/2017

These instructions remain the property of Rhino-Rack Australia Pty Ltd and may not be used or changed for any other purpose than intended.



RTS518 - Rhino Heavy Duty Crossbar System

Parts List

Item	Component Name	Qty 2 Bar	Qty 3 Bar	Part No
1	Hyundai Track 2345mm	1 Pair	1 Pair	A406
2	Track End Cap (left)	2	2	C393
3	Track End Cap (right)	2	2	C394
4	Rubber Buffer Strip 1500mm	2	3	R001
5	Crossbar 1500mm	2	3	A022
6	End Cap	4	6	M002
7	M6x35mm Security Screw	8	12	B092
8	M6 Spring Washer	8	12	W004
9	M6 x 12.5mm FLat Washer	8	12	W003
10	Track Mount Wedge	8	12	M148
11	M6x21.43mm x 4.40mm Brass Nut	8	12	N009
12	M10 Channel Nut	4	6	N025
13	Heavy Duty Leg Height Spacer	0	6	M016
14	RLTF Leg	4	6	M010
15	M10x38mm Flat Washer	4	6	W022
16	M10 internal shakeproof washer	4	6	W021
17	M10x35mm bolt	0	2	B079
18	M10x25mm bolt	4	2	B071
19	M10x45mm bolt	0	2	B080
20	5mm Rivet	16	16	H008
21	5mm Security Allen Key	1	1	SECKEY-S
22	Butyl Patches	17	16	CA1397
23	Fitting Instruction	1	1	RR179

Tools Required:

Pneumatic or Concertina rivet gun.
 Marking pen.
 Power or Cordless drill.
 5mm drill with **drill depth stop**.
 Vacuum cleaner.
 Cold galvanizing solution & brush.
 Hammer & Pin Punch Ø4-5 mm.
 Silastic Sealer/Selleys Butyl Mastic.
 5mm Security allen key, provided in kit.
 5/8 or 16mm spanner.
 Measuring tape.
 Hacksaw.
 Philips head screwdriver.
 Flat head screwdriver.

Drill depth stop.

Round piece of wood or plastic of larger outer diameter than the hole being drilled.
 5-6 mm hole through centre.

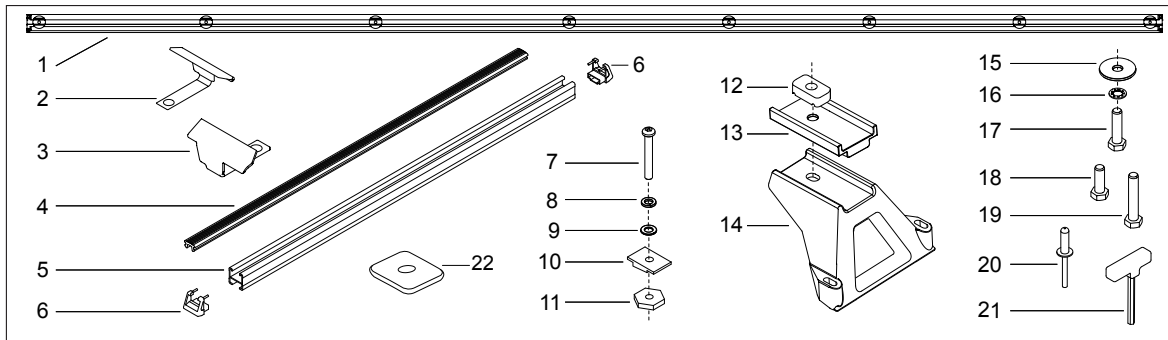
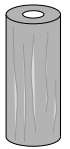

1 Completely remove roof channel trim.

Start by lifting the front edge of rubber trim. Carefully twist rubber trim in an outward direction to unhook the plastic clips. Retain the front three clips on each side to secure the cut trim back in place after installation of the track.

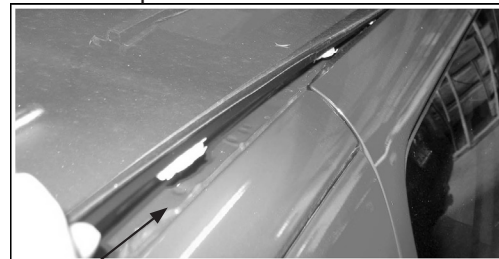

Lift front of the trim from outside edge of roof. Twist outwards to unhook as shown in the diagrams.

The roof channel must be totally clean of any dirt, so be sure to wash thoroughly and completely dry off before track installation.

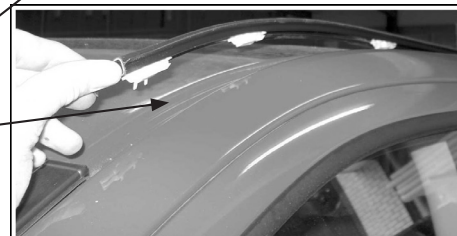



RTS518 - Rhino Heavy Duty Crossbar System

2 Track and end cap orientation.

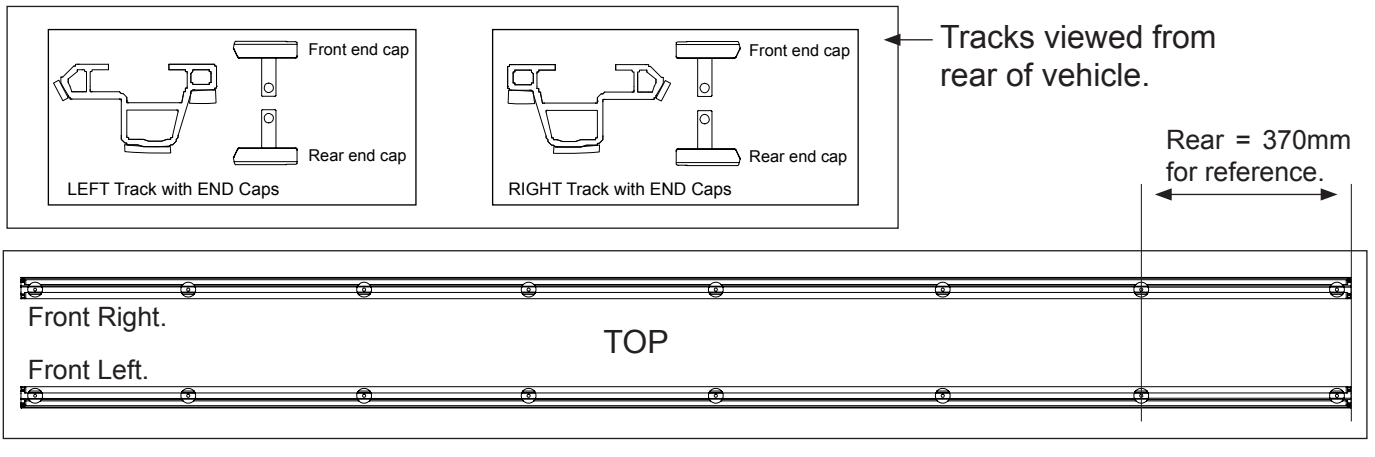

3

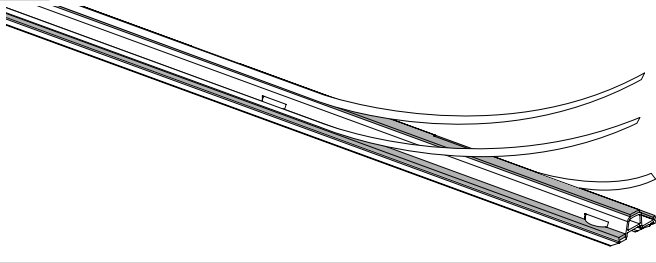

Remove backing strip.

Remove the white backing strip from the foam tape on the underside of the track.

4

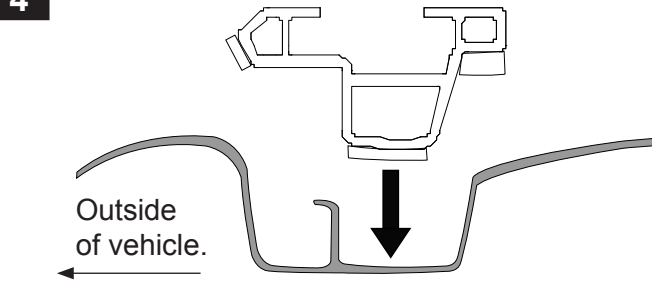

Track location.

Locate the track extrusion into the roof channel and up against the rib running through.

LEFT track extrusion as viewed from rear.

5 Track positioning.

- Place the track in the roof channel. Line up track and end of roof channel at the rear.
- Open side doors. Depress the rubber seal and fit outside edge of the track underneath.
- Unless you have assistance from another person, masking tape can be used to hold the track firmly in position while spot drilling the holes.

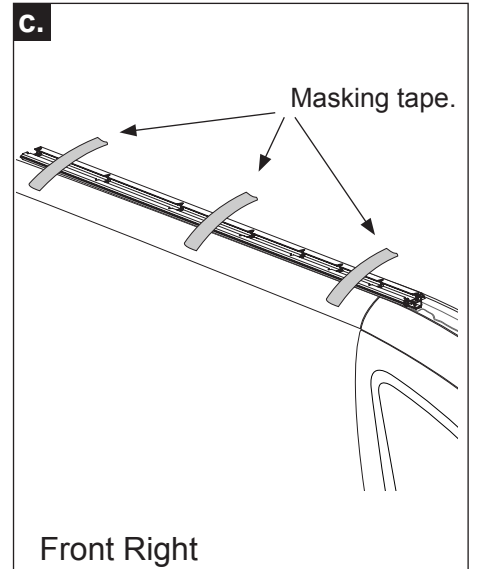
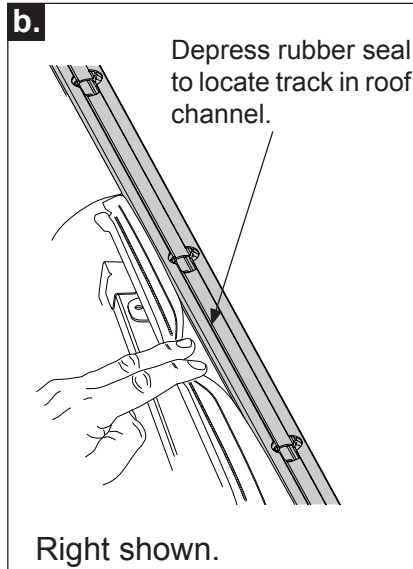
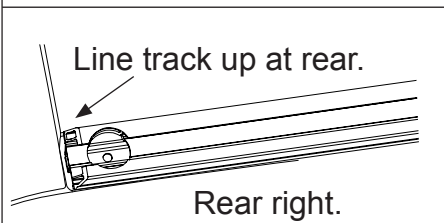
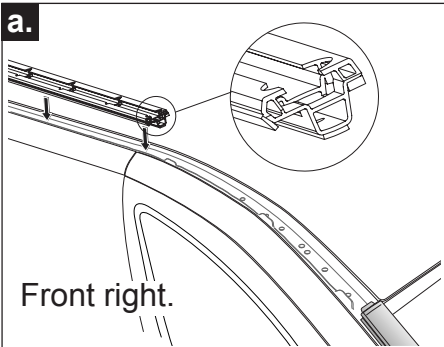



RTS518 - Rhino Heavy Duty Crossbar System

6



Spot drill roof.

With the track in place, use a 5 mm drill bit to spot drill all 8 holes **starting at the rear**. Check each hole to make sure the track isn't moving at all.

Maintain 90° to the surface being drilled.

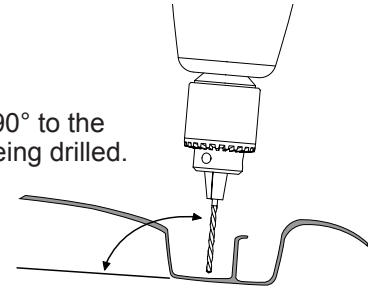

7

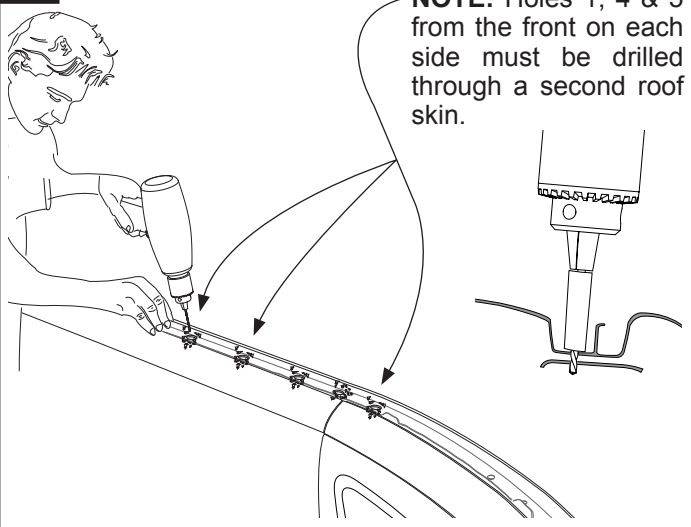

NOTE: Holes 1, 4 & 5 from the front on each side must be drilled through a second roof skin.

Drill through roof.

Remove the track. Use of a drill stop is recommended to avoid drilling into hood lining. When drilling hold the drill perpendicular to the surface being drilled. Drill through the roof skin using a 5 mm bit.

8-10 mm

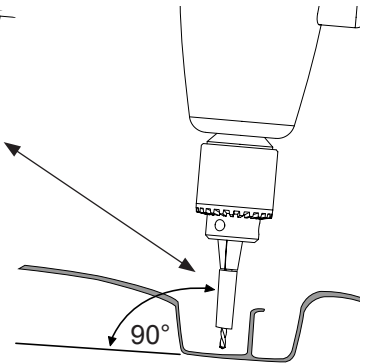

8

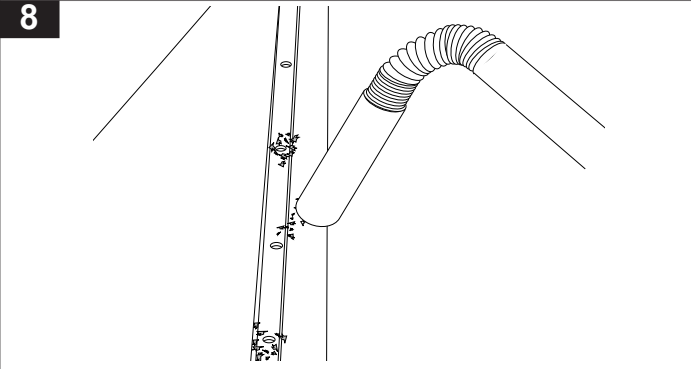

Vacuum swarf.

Use a vacuum cleaner to remove swarf from the roof. This will minimise swarf entering the hole and avoid scratching. Wipe the channel clean with a damp cloth.

9

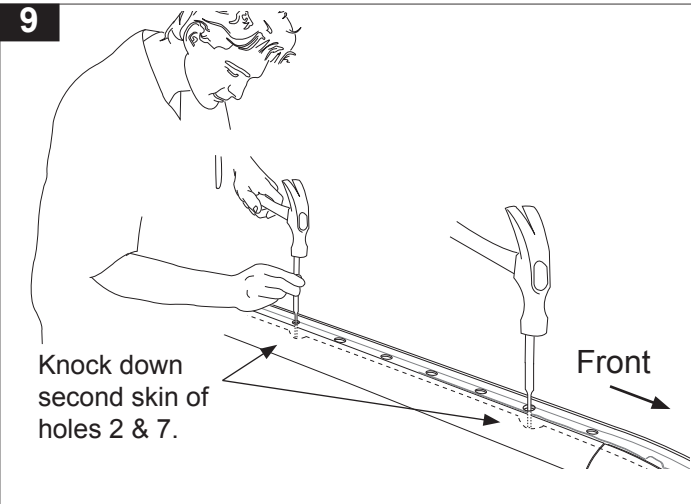

Knock down second skin of holes 2 & 7.

Front

Pin punch 2 holes.

Two spots on the second skin of the roof have to be hit and dented for clearance on the rivet. Use a Pin punch of Ø4-5 mm.

As shown in the diagram at left, carefully hit holes 2 & 7 from the front on each side.

Gap of 0-3 mm between top roof skin and rivet head.

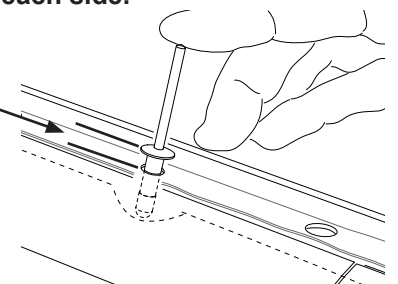



RTS518 - Rhino Heavy Duty Crossbar System

10a Apply sealer.

STEP 1. Apply a liberal amount of cold galvanizing solution to the inside and surrounds of all holes. Allow cold galvanizing solution to touch dry, ten minutes or so, **STEP 2.** Apply a liberal amount of Selleys Butyl Mastic sealer in each hole.

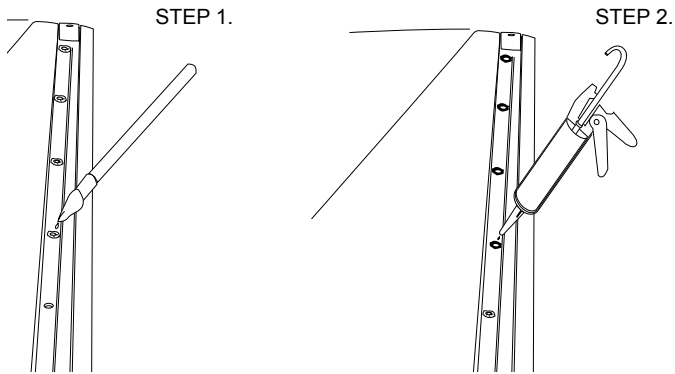

10b 1: Remove the backing tape from the ButylPatches. 2: Place over holes drilled. Once in place remove the rest of the protective tape from the top of the patches.

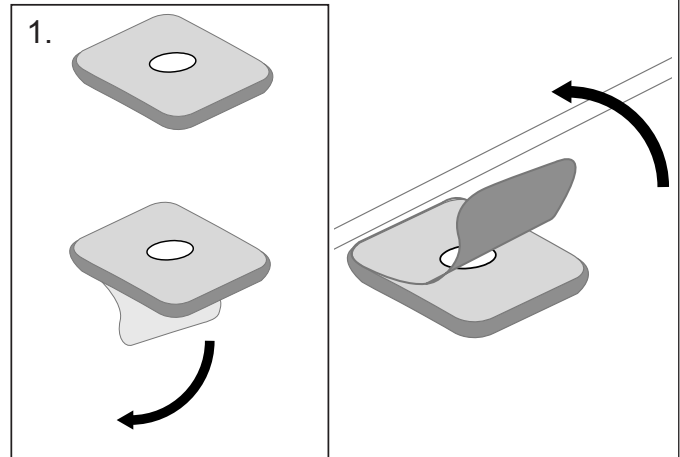

11 Fasten track with end caps.

Locate the end caps, refer **Step 2 for Left and Right end caps**. The tongue of the end cap sits inside on top of the bottom surface of the track and is riveted together. Place track over holes, align track by inserting all rivets. Start riveting from the rear to front as shown below.

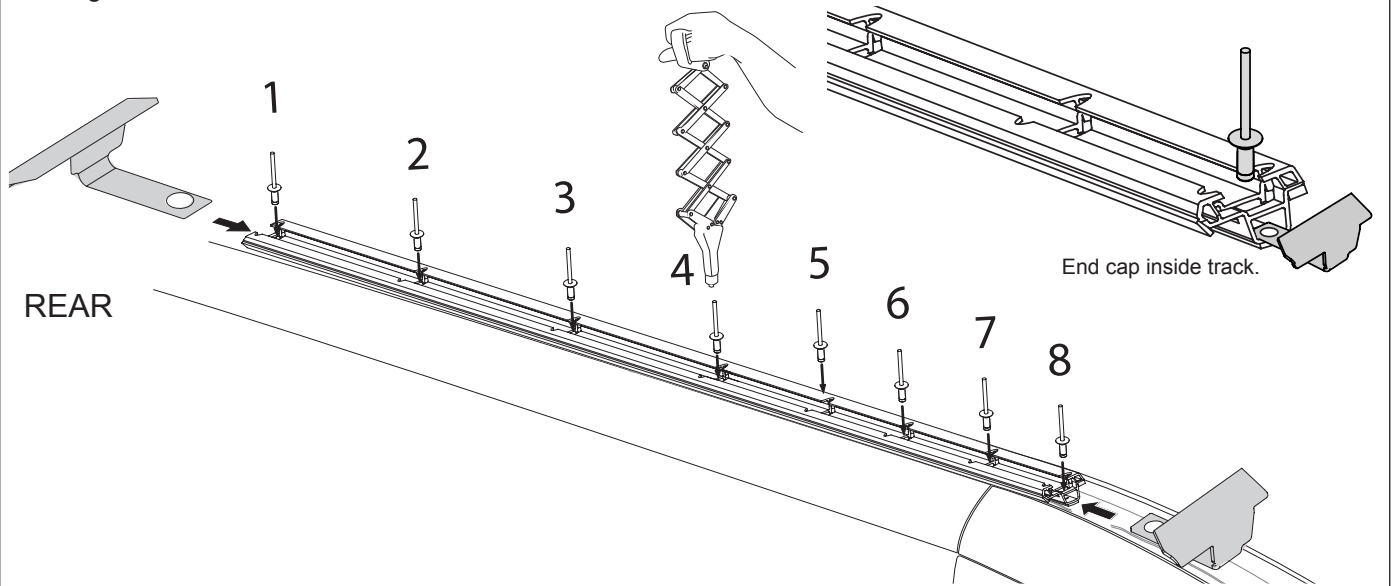

12 Cut and re-fit roof trim.

Lay the roof trim over the roof channel with the front against existing trim. Measure this distance and mark a line using a pencil. Use a hacksaw to cut through trim. Re-fit the cut roof trim.

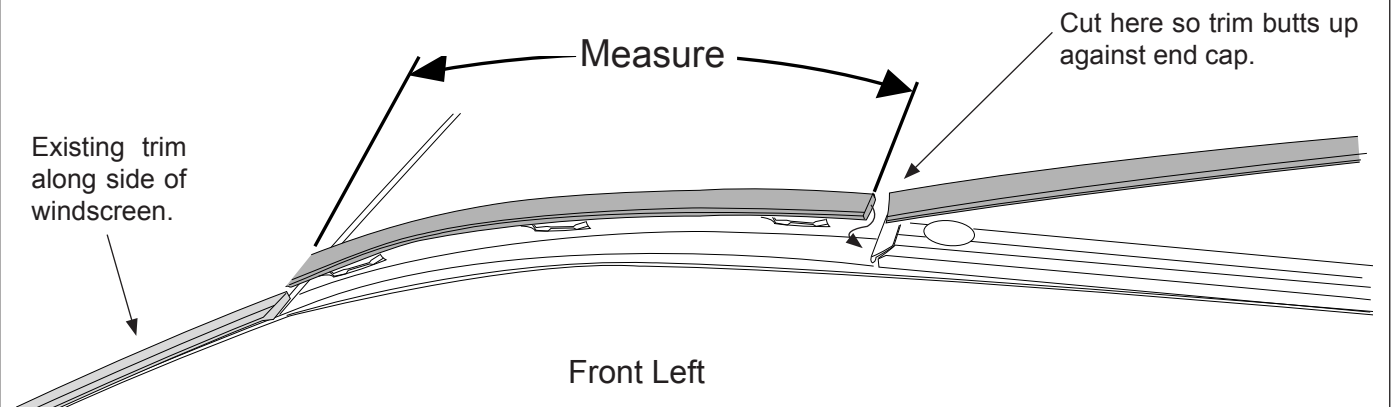



RTS518 - Rhino Heavy Duty Crossbar System

13

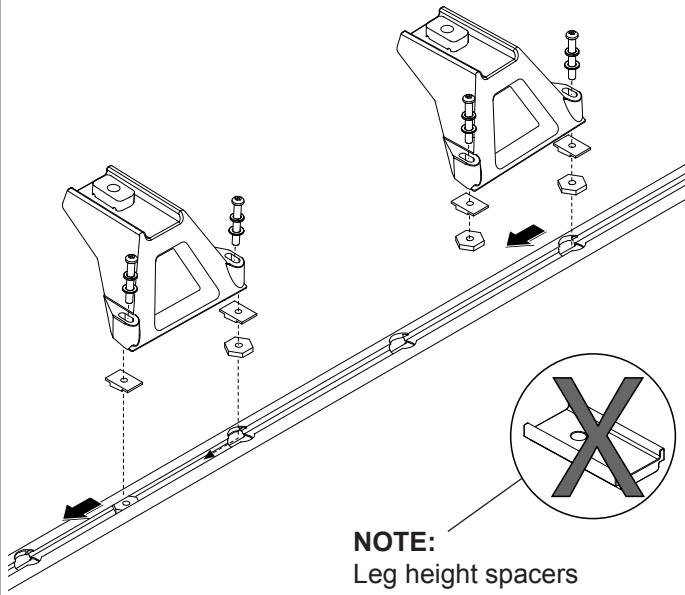

NOTE:
Leg height spacers not needed for two bar system.

Attach legs.

Remove brass hex nuts from the leg. Place hex nuts into any of the round cut outs of the track and slide to position. Make sure the legs are parallel across the vehicle and hex nuts are clear of all holes after positioning.

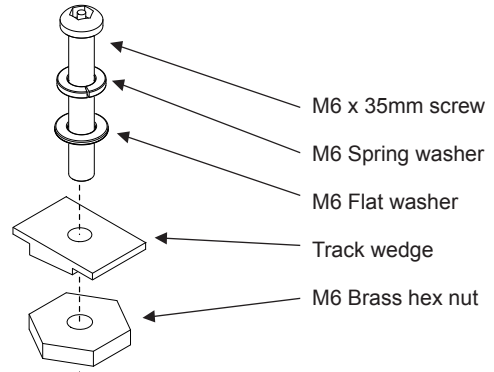

14 Leg positioning 2 crossbars.

Use the measurements below to position the legs before fitting crossbars. Maximum load is 100kg evenly distributed over the two crossbars. **DO NOT TIGHTEN LEG BOLTS** at this stage.

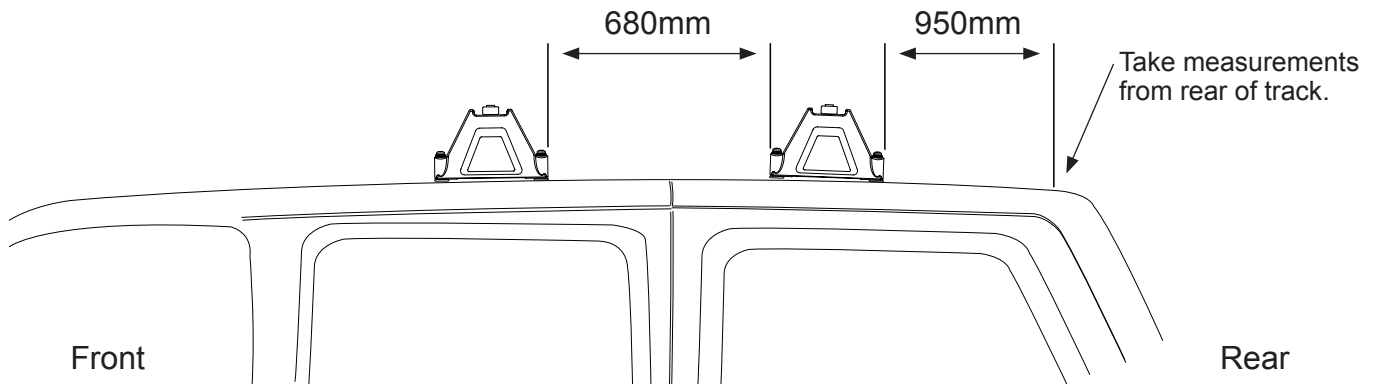

15 Leg height spacers, 3 bar system only.

Front crossbar uses one leg height spacer. Middle crossbar no spacer. Rear crossbar, two spacers.

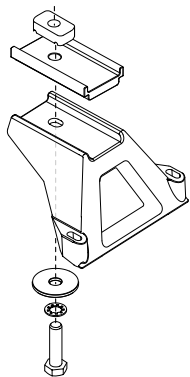

Front crossbar,
M10 x 35mm bolt.

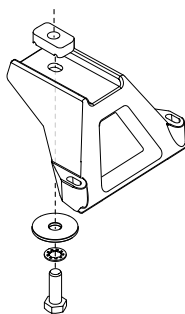

Middle crossbar,
M10 x 25mm bolt.

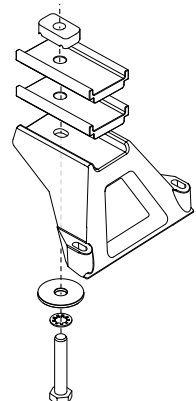

Rear crossbar,
M10 x 45mm bolt.



RTS518 - Rhino Heavy Duty Crossbar System

16 Leg positioning, 3 crossbars.

Use the measurements below to position the legs before fitting crossbars. Maximum load 125kg evenly distributed over the three crossbars. **DO NOT TIGHTEN LEG BOLTS** at this stage.

NOTE: The positioning is important as it maintains a level height over the 3 crossbars.

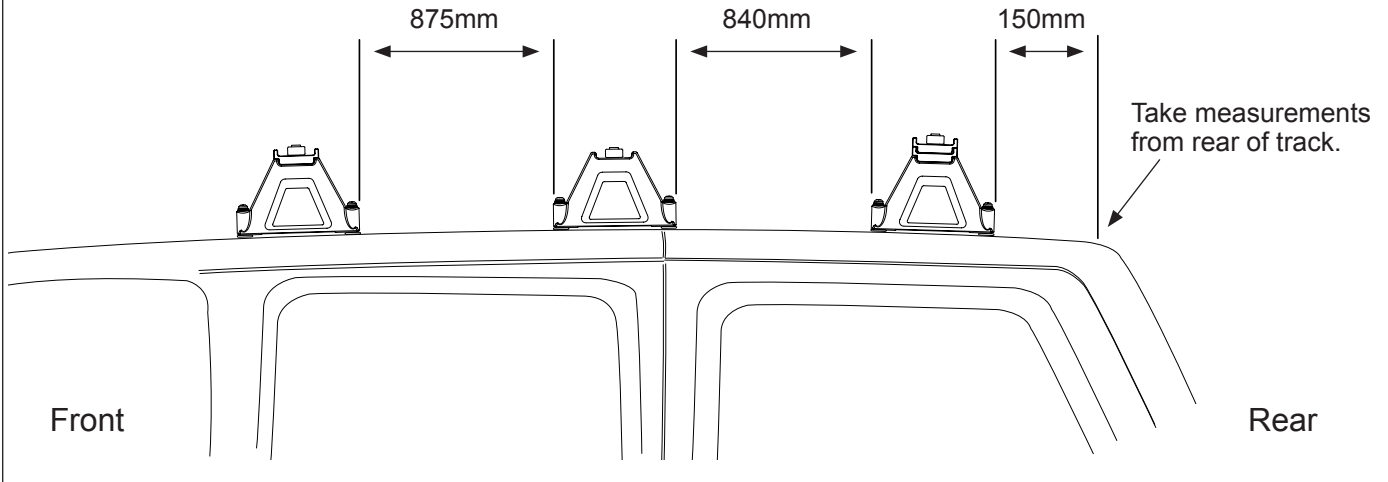

17

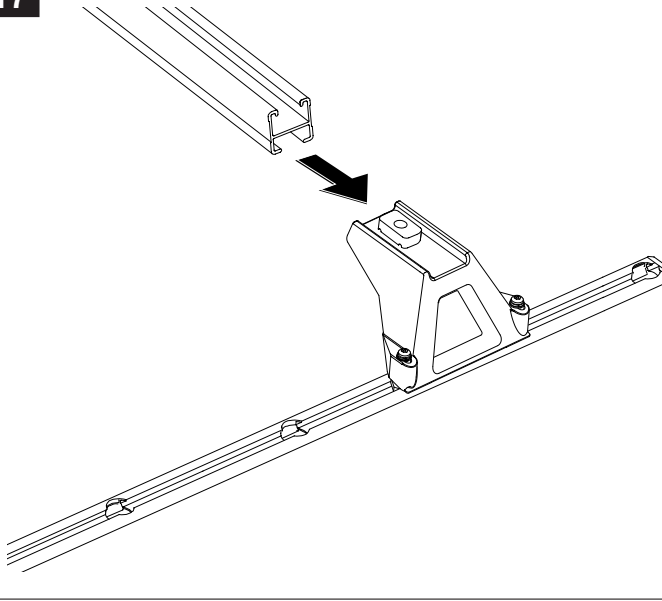

Attach crossbar.

Place crossbar onto leg. Locate M10 channel nut. Finger tighten at this stage.

Channel nut must fully locate across the bar.

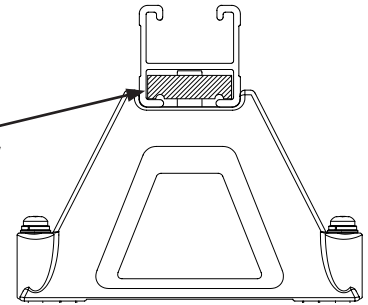

18

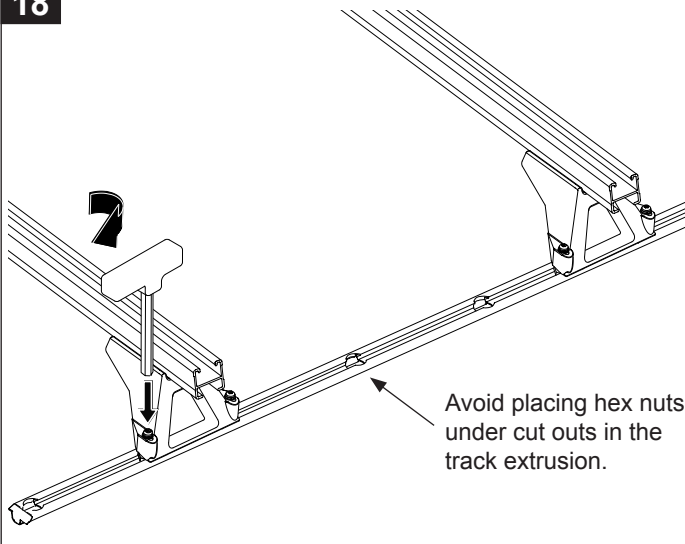

Tension crossbar and legs.

Locate RLTF legs parallel across the vehicle. Fasten M6 security screws into the brass hex nuts.



RTS518 - Rhino Heavy Duty Crossbar System

19 Check overhang.

Measure to get equal crossbar overhang. Tighten M6 x 35mm leg screw to **3-4 Nm**. Tighten M10 cross bar bolts to **15-17 Nm**.

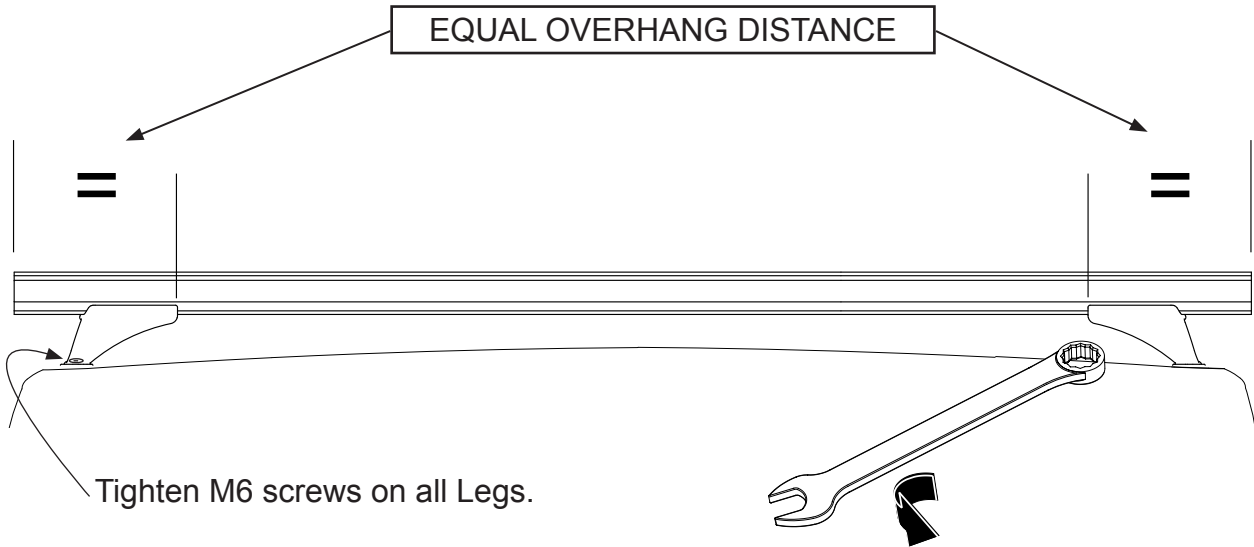

20

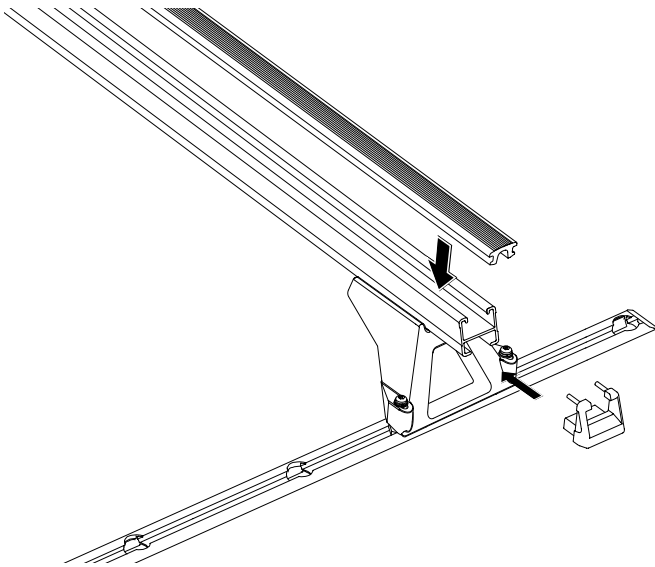

Fit rubber buffer and end caps.

Insert rubber into top of the crossbar. Insert end caps into end of each crossbar. A rubber mallet may be required to fit the end caps.

Channel nut must be fully located across the bar as shown.

