



# RHINO-RACK

Aerodynamic & Heavy Duty Roof Rack Systems

## RSS158 Mazda 6 Sedan & Hatch Rhino Sports - Two Bar System.

**Important:** Please read these instructions carefully prior to installation.  
Please refer to your fitting instruction to ensure that the cross bars are installed in the correct locations.  
Check the contents of kit before commencing fitment and report any discrepancies.  
Place these instructions in the vehicle's glove box after installation is complete.

### Layout

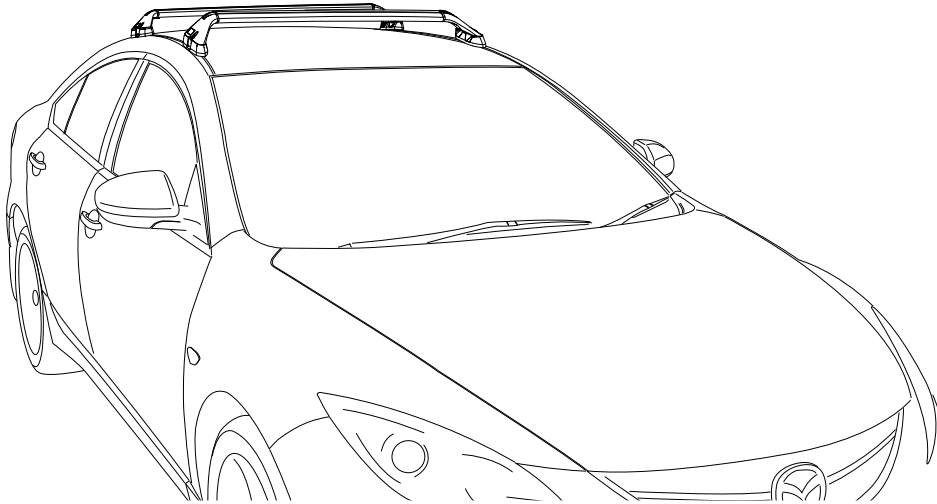

### IMPORTANT Care Instruction:

Clean roof mounting area prior to fitting the Sports bars. **PLEASE READ THROUGH INSTRUCTIONS BEFORE FITTING.**

### Important Information

**Maximum carrying capacity: 75kg evenly distributed over the two cross bars.**

#### Recommendations:

It is essential that all bolt connections be checked after driving a short distance when you first install your cross bars. Bolt connections should be checked again at regular intervals (probably once a week is enough, depending on road conditions, usage, loads and distances travelled). You should also check the cross bars each time they are re-fitted.  
Make sure to fasten your load securely. Please ensure that all loads are evenly distributed over the two cross bars and that the centre of gravity is kept as low as possible.

**Use only non-stretch fastening ropes or straps.**

#### Caution:

The handling characteristics of the vehicle change when you transport a load on the roof. For safety reasons, we recommend exercising extreme care when transporting large wind-resisting loads; special consideration must be taken into account when negotiating corners and under braking.

**Please remove cross bars when putting vehicle through an automatic car wash.**

#### Load Ratings:

Maximum permissible load is **75kg evenly distributed over the two cross bars**. When cross bars are to be used in off-road conditions, please build a safety factor of 1.5 into this load limit. 50kg maximum for off-road conditions. Although the cross bars are tested and approved to AS1235-2000, Australian road conditions can be much more rigorous. However, increasing the number of cross bars does not increase the vehicles maximum permissible roof loading.

#### Note for Dealers and Fitters:

**It is your responsibility to ensure instructions are given to the end user or client.**

Rhino-Rack  
3 Pike Street, Rydalmere,  
NSW 2116, Australia.  
(Ph) (02) 9638 4744  
(Fax) (02) 9638 4822

Document No: RS-338  
Prepared By: Craig Jones  
Authorised By: Gary England

Issue No: 02  
Issue Date: 31/07/2009

These instructions remain the property of Rhino-Rack Australia Pty. Ltd. and may not be used or changed for any other purpose than intended.



# RSS158 Mazda 6 Sedan & Hatch Rhino Sports - Two Bar System

## Parts List

Maximum carrying capacity: 75kg

Item	Component Name	Qty	Part No.
1	Buffer Strip REAR 872mm	1	R011
2	Buffer Strip FRONT 880mm	1	R011
3	Sports Cross Bar REAR 872mm	1	A155
4	Sports Cross Bar FRONT 880mm	1	A155
5	Mazda Roof Pad LEFT	2	M049-2H-S
6	Mazda Roof Pad RIGHT	2	M050-2H-S
7	RSS Sports Leg RIGHT	2	M014
8	RSS Sports Leg LEFT	2	M013
9	M6 x 55 Security Screw	4	B138
10	M6 Spring Washer	4	W004
11	M6 x 12.5mm Flat Washer	4	W003
12	10G x 1/2" Phillips Screw	4	B045
13	Mazda Roof Pad Cover Plate	4	C411
14	5mm Security Allen Key	1	Seckey-S
15	Fitting Instruction	1	RS-338

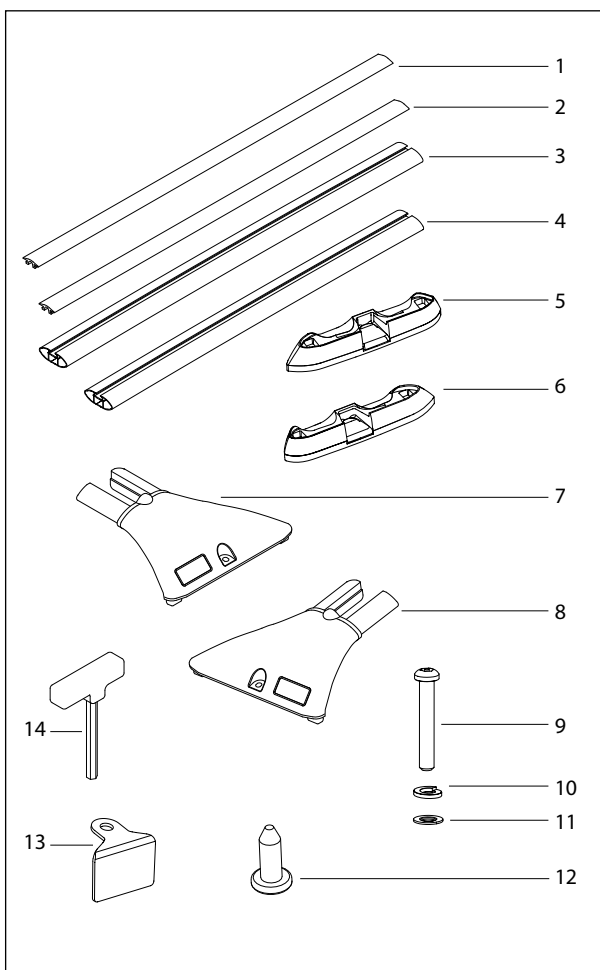

### Tools Required;

Allen key, provided in kit.  
Phillips Head Screwdriver.  
Rubber Mallet.

- 1 Locate the plastic covers on the roof gutter trim. Use light pressure and slide the cover in the direction of the arrow. Remove the cover.

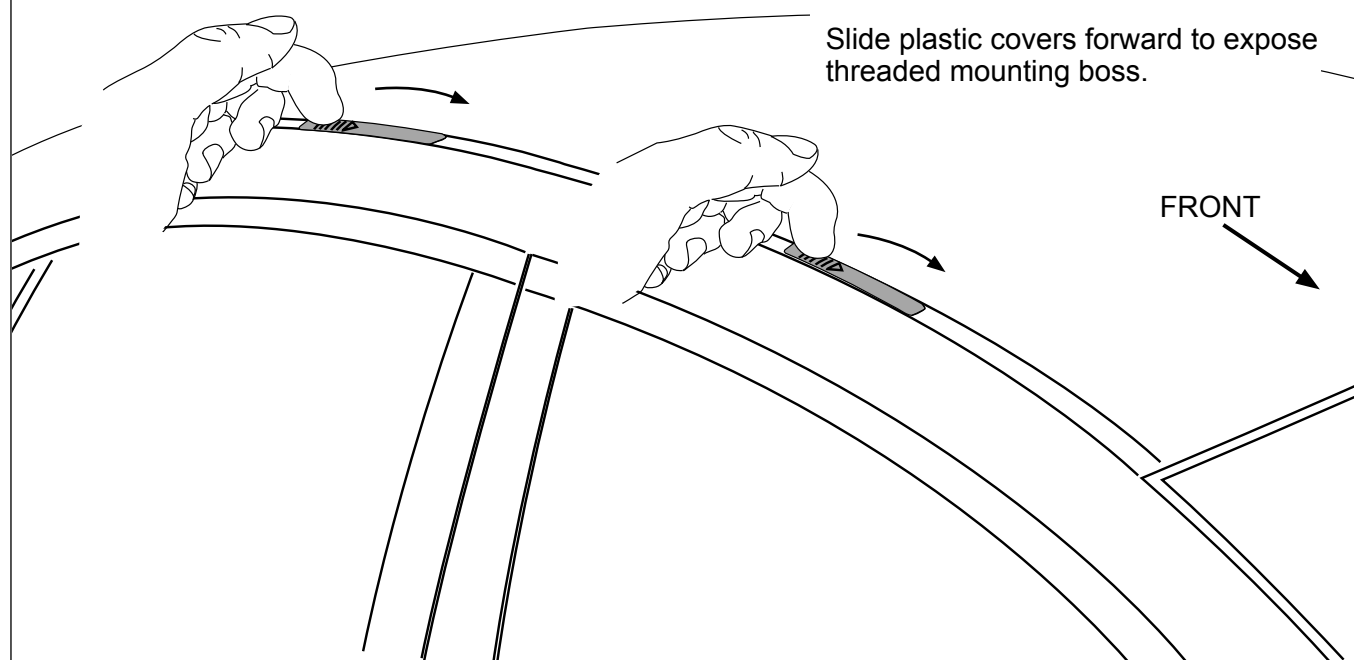



## RSS158 Mazda 6 Sedan & Hatch Rhino Sports - Two Bar System

2

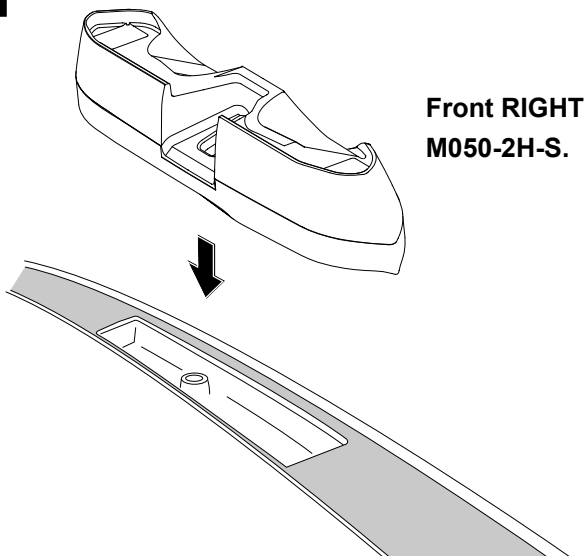

Place the correct roof pad over the exposed area where the nutsert is. **The pads are marked on the underside with Part Numbers to denote their position on the roof.** There is also an arrow on each pad which must point forward once installed.

RIGHT Pads - M050-2H-S  
LEFT Pads - M049-2H-S

3

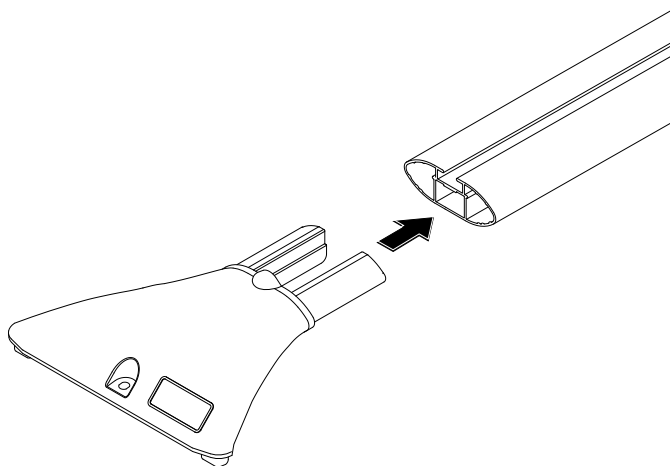

Insert the Sports leg fully into the cross bar, a rubber mallet may be required to knock the leg in place.

Long leading edge  
of Front & Rear  
Leg towards front  
of vehicle.

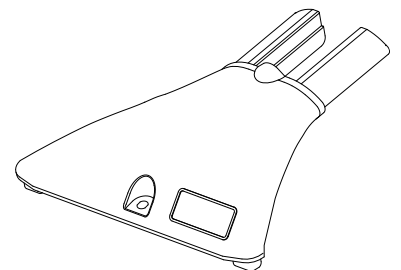

4

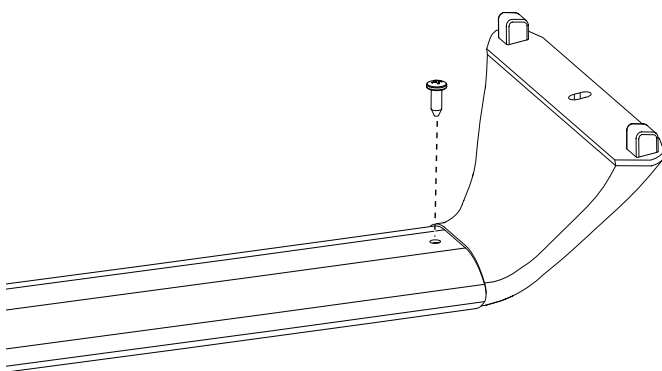

From the underside of the cross bar insert the phillips head screw.



# RSS158 Mazda 6 Sedan & Hatch Rhino Sports - Two Bar System

5

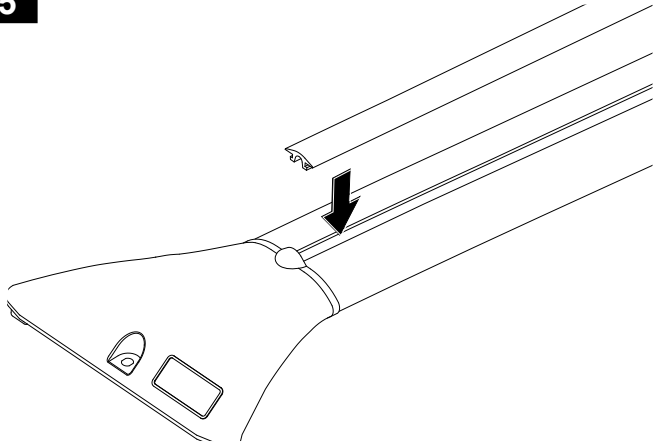

Insert the correct rubber buffer strip into the top of the cross bar.

FRONT Buffer Strip = 880mm

REAR Buffer Strip = 872mm

6

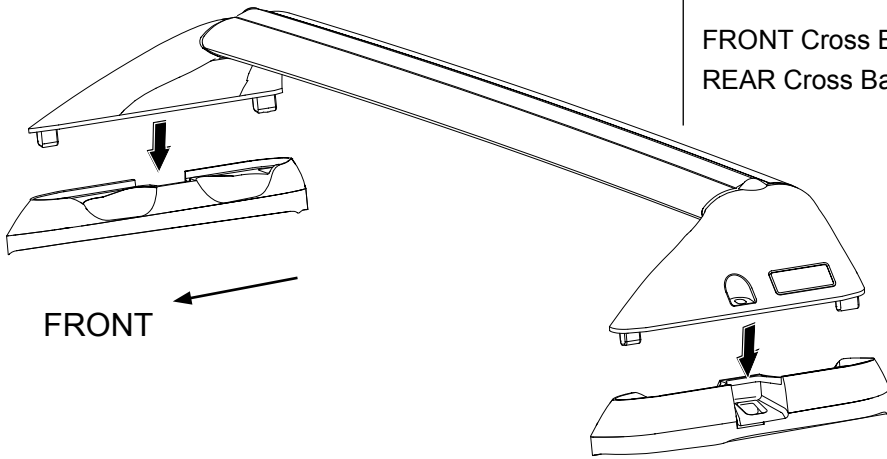

Place the assembled cross bars onto the front and rear roof pads.

FRONT Cross Bar = 880mm

REAR Cross Bar = 872mm

7

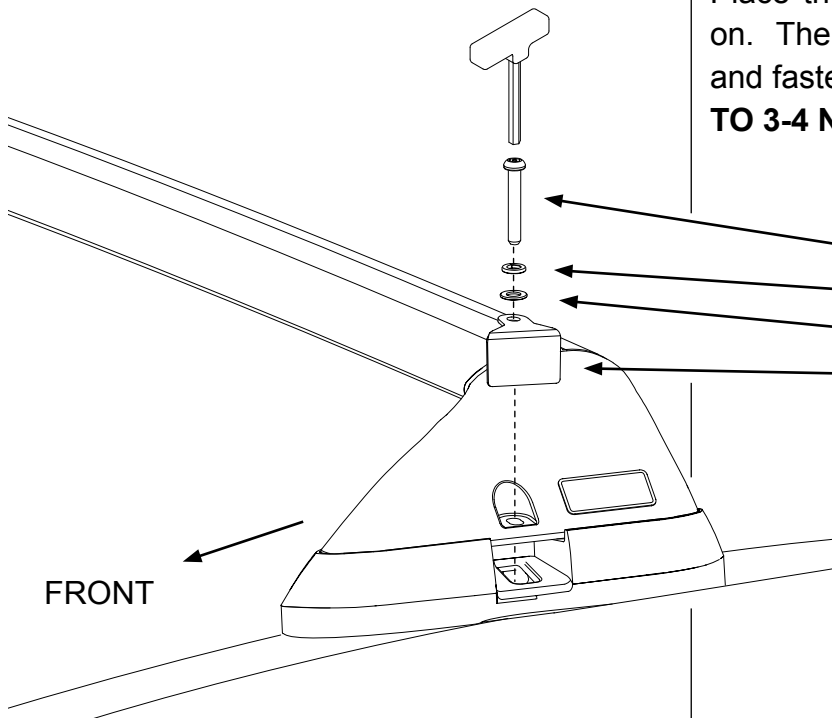

Place the stainless steel roof pad cover plate on. Then put the M6 screw assembly through and fasten to the nutsert in the roof. **TIGHTEN TO 3-4 Nm. DO NOT OVER TIGHTEN.**

M6 x 55 Security screw

Spring washer

Flat washer

Roof pad cover plate