



# RHINO-RACK

Aerodynamic & Heavy Duty Roof Rack Systems

## RSPT508 Range Rover Sport 2 Bar Sportz System

Place these instructions in the vehicle's glove box after installation is complete.

**Important:** Please read these instructions carefully prior to installation. Please refer to your fitting instruction to ensure that the roof racks are installed in the correct locations. Check the contents of kit before commencing fitment and report any discrepancies

### Parts List

Maximum carrying capacity: 75kg

Item	Component Name	Qty	Part No.
1	FRONT Buffer Strip 1060mm	1	R011
2	REAR Buffer Strip 1045mm	1	R011
3	FRONT Cross Bar 1060mm	1	A155
4	REAR Cross Bar 1045mm	1	A155
5	M6 x 35mm Security Screw	4	B092
6	M6 Spring Washer	4	W004
7	M6 x 12.5mm Flat Washer	4	W003
8	RSP Sportz Leg	4	M094
9	RSP Top Pad	4	M173
10	RSP Bottom Pad	4	M172
11	M6 x 16 Dowel Nut	4	N027
12	Dowel Nut Housing	4	A341
13	10G x 1/2" Pan Head Phillips Screw	4	B045
14	5mm Security Allen Key	1	SecKey-S
15	Fitting Instruction	1	RS-294

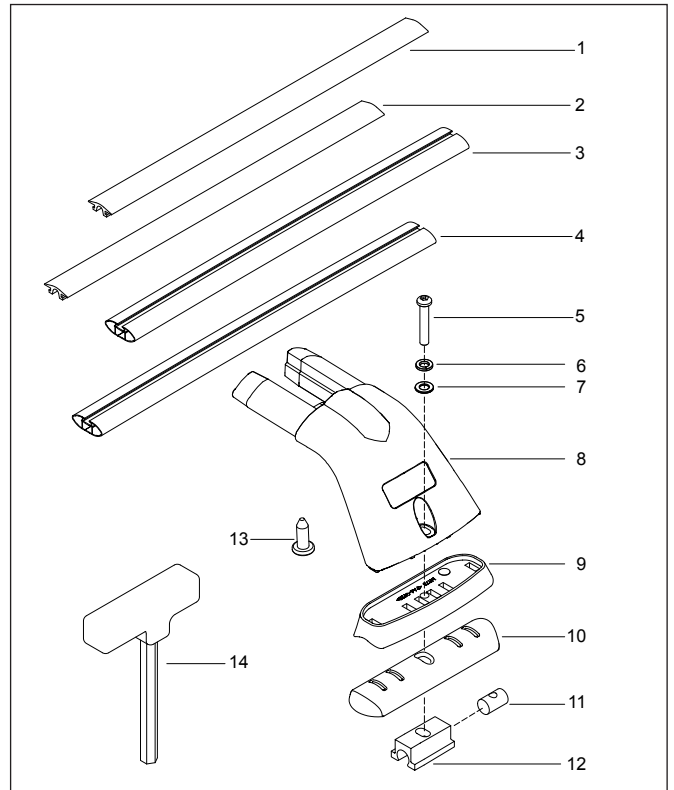

### Care Instruction:

Clean vehicle roof and gutter prior to fitting Rhino Tracks.

### Tools & Materials Required.

5mm Security Allen key, provided in kit.  
Phillips Head screw driver.  
Measuring tape.

### Layout

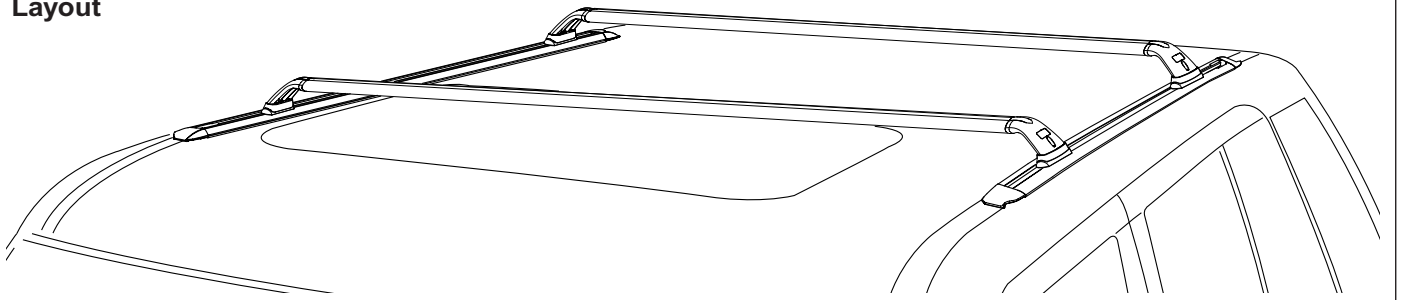

1

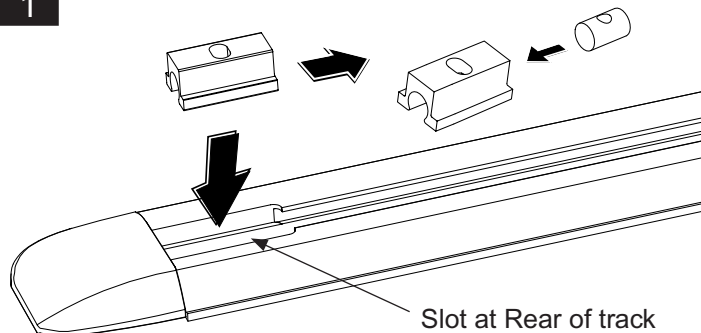

Slide the Dowel Nut into the Dowel Nut Housing with the thread facing up through the hole. Place the Dowel Nut Housing into the slot of the track and slide along to desired position.



## RSPT508 Range Rover Sport 2 Bar Sportz System

2

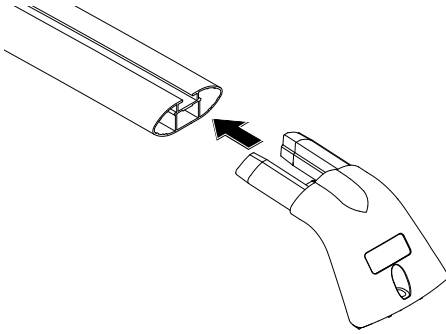

Insert the Sportz leg fully into the Front and Rear cross bar, a rubber mallet may be required to knock the leg in place.

3

From the underside of the crossbar insert the Phillips head screw.

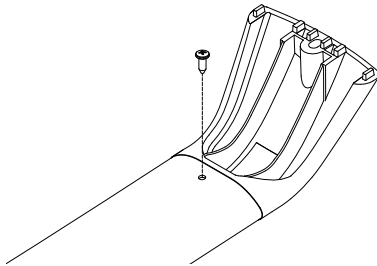

4

Insert the Front and Rear rubber buffer strip into the top of their respective cross bar.

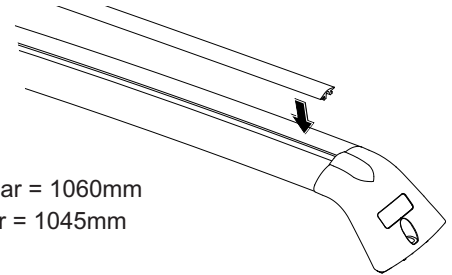

FRONT Cross Bar = 1060mm

REAR Cross Bar = 1045mm

5

Place the Bottom Pad over the Dowel Nut Housing then Top Pad. Sit the Leg/Cross Bar assembly on the Top Pad. Place the M6 Security Screw and washers through the hole in the Leg as shown and screw into the Dowel Nut. Tightening torque is 3-4Nm. Tighten after positioning both sides equally.

Tangs face towards outside of vehicle

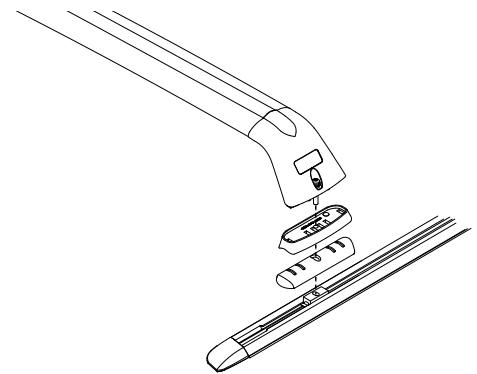
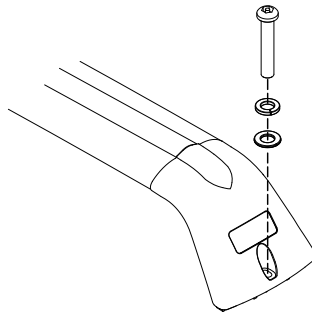

6

With the assembled cross bars on the tracks, slide them along to the following measurements. Measure 185mm from each end of the track to the M6 screw in the leg as shown. Make sure the cross bars are parallel, measure each side of the vehicle. **Tighten the M6 screw to 3-4 N/m.**

FRONT 1060mm

REAR 1045mm

