



RHINO-RACK

Aerodynamic & Heavy Duty Roof Rack Systems

RSP05 Range Rover Sportz Bars

Place these instructions in the vehicle's glove box after installation is complete.

Important: Please read these instructions carefully prior to installation. Please refer to your fitting instruction to ensure that the roof racks are installed in the correct locations. Check the contents of kit before commencing fitment and report any discrepancies

Maximum carrying capacity: 100kg

Parts List

Item	Component Name	Qty	Part No.
1	Mounting Stud	6	C358
2A	Mounting Pad Front Right/Rear Left	2	M168
2B	Mounting Pad Centre	2	M166
2C	Mounting Pad Front Left/Rear Right	2	M167
3	Leg	6	M094
4A	M6 x 35 Security Screw Centre Pads	2	B092
4B	M6 x 50 Security Screw Front & Rear Pads	4	B128
5	M6 Spring Washer	6	W004
6	M6 Flat Washer	6	W003
7	10g x 1/2" Self Tapping Screw	6	B045
8A	Sports Bar 1043mm Front	1	A155
8B	Sports Bar 1013mm Centre	1	A155
8C	Sports Bar 965mm Rear	1	A155
9	Buffer Strip	3	R011

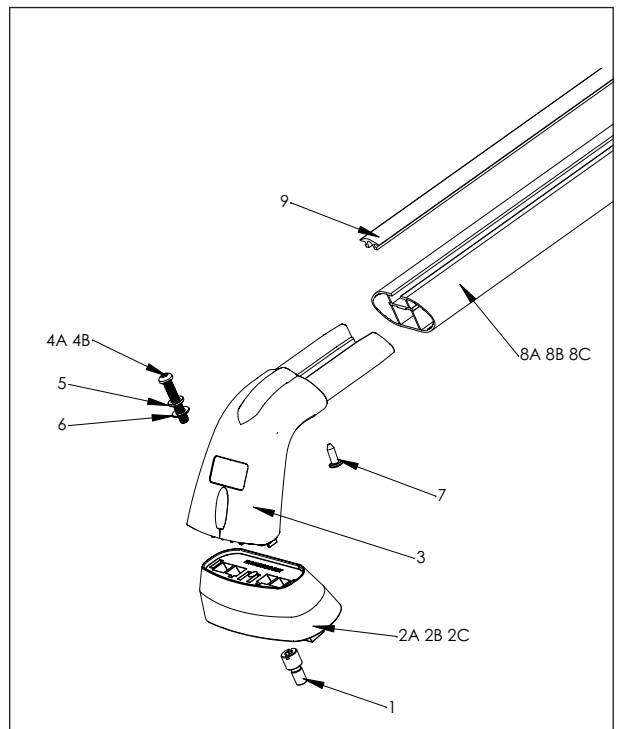

Layout

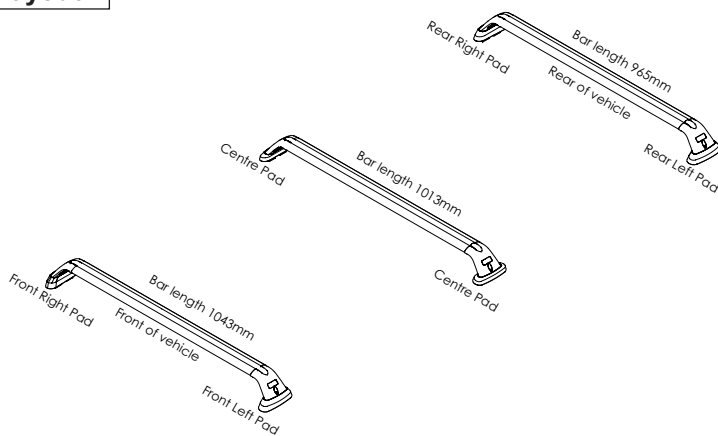

Care Instruction:

Wash and clean vehicle roof prior to fitting the Rhino Sportz roof racks.

Tools Required

Allen key, provided in kit
Phillips head & flat bladed screwdrives

From the top of the vehicle, fold open each plastic flap and remove the grub screws from the bottom of the cavities with the Allen key provided. Remove any excess body filler from the bottom of the cavities. Screw the brass mounting studs into the threaded holes, and tighten lightly with a flat-bladed screw driver.

1

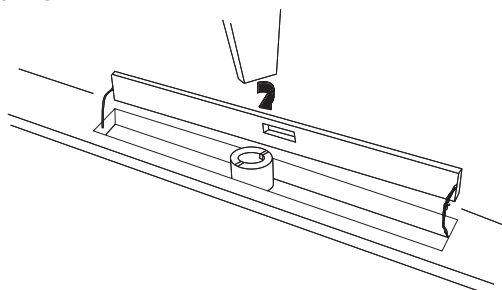

Install each pad into each cavity, ensuring that the plastic flap is folded right up and the curved portion of the pad's top recess is towards the outside of the vehicle.

2

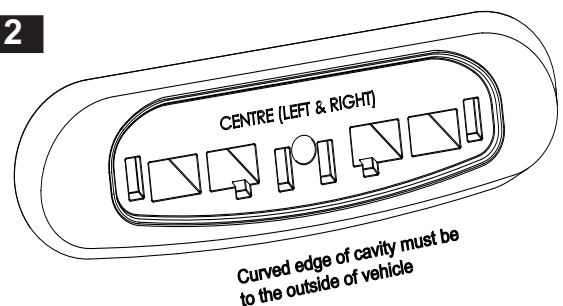

Insert the support leg fully into the cross bars. A rubber mallet may be required to knock the leg into place.

3

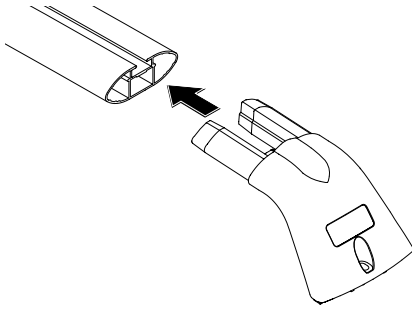

From the under side of the cross bar insert the philips-head screw and tighten carefully.

4

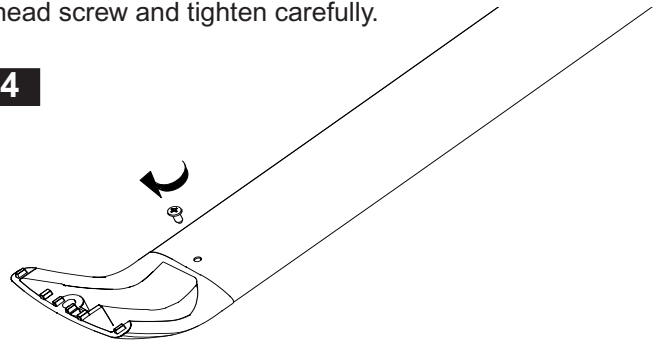

Insert the rubber buffer strip into the top of each cross bar.

5

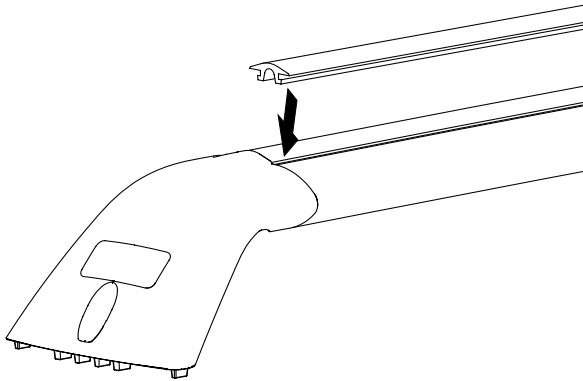

Place the cross bars onto the pads. Note that the cross bar lengths are different front, centre and rear. Refer to layout drawing for correct positioning.

6

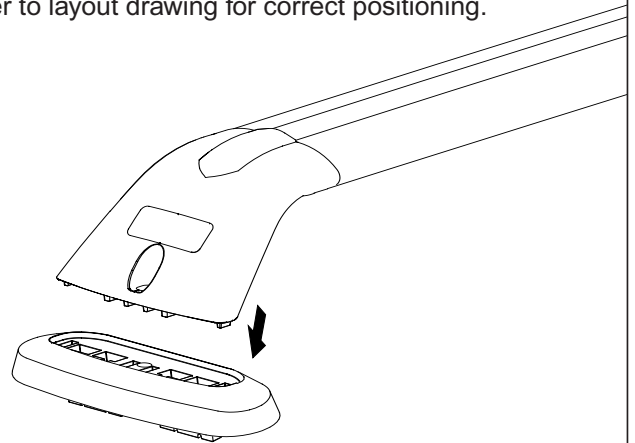

Assemble the spring washers and the flat washers onto the security screws, slipping the spring washer on first. Insert the screws into the support leg mounting holes and screw down into the brass mounting studs under the pads, using the security Allen key provided. **NOTE** The shorter **35mm screws** go into the **centre pads** and the longer **50mm screws** go into the **front and rear pads**. Do not over-tighten .

7

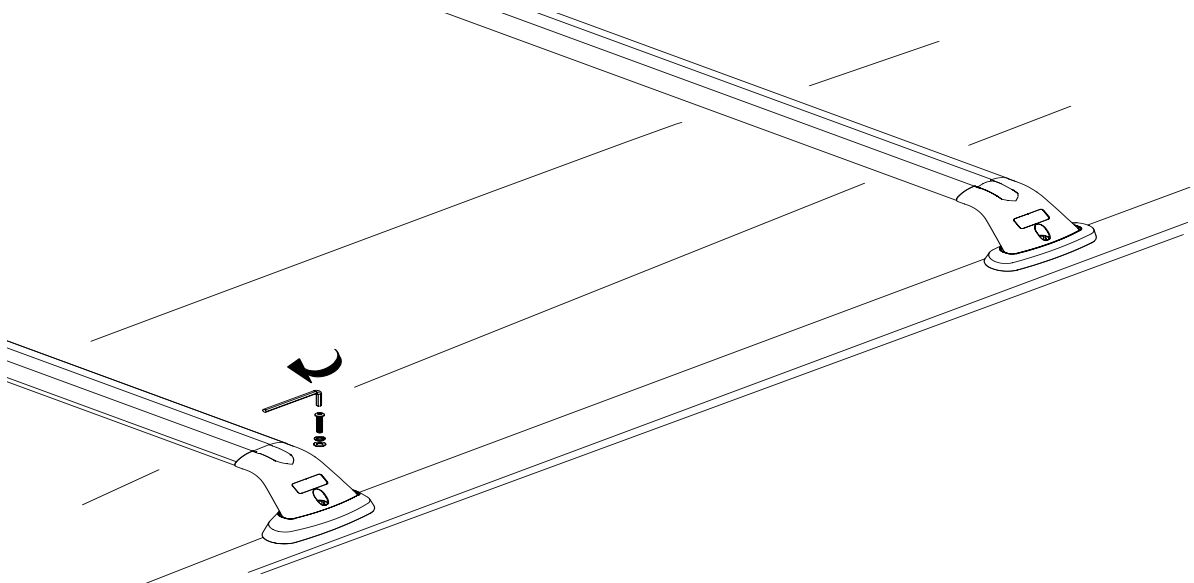

Important Information

Maximum carrying capacity: 100kg

Recommendations

It is essential that all bolt connections be checked after driving a short distance when you first install your crossbars. Bolt connections should be checked again at regular intervals (probably once a week is enough, depending on road conditions, usage, loads and distances travelled). You should also check the roof bars each time they are refitted.

Make sure to fasten your load securely. Please ensure that all loads are evenly distributed and that the centre of gravity is kept as low as possible.

Use only non-stretch fastening ropes or straps.

Sensitivity to Crosswinds, Behaviour in Curves and Braking

The handling characteristics of the vehicle, changes when you transport a load on the roof. For safety reasons, we recommend you exercise extreme care when transporting wind-resisting loads; special consideration must be taken into account when braking.

Please remove crossbars when putting vehicle through an automatic car wash.

Load Ratings

Maximum permissible total load is 100kg for the 3 bars (include the weight of the roof bars, 8kg). When roof racks are to be used in off-road conditions, please build a safety factor of 1.5 into this load limit. Although the roof racks are tested and approved to AS1235-2000, Australian road conditions can be much more rigorous. However, increasing the number of crossbars does not increase the vehicles maximum permissible roof loading.

Note for Dealers and Fitters

It is your responsibility to ensure instructions are given to the end user or client

Rhino-Rack
3 Pike Street, Rydalmere,
NSW 2116, Australia.
(Ph) (02) 9638 4744
(Fax) (02) 9638 4822

Document No: RS-74
Prepared By: Ken Phillips
Authorised By: Gary England

Issue No: 03
Issue Date: 23/03/2007

These instructions remain the property of Fetovu Pty Ltd T/as Rhino-Rack and may not be used or changed for any other purpose than intended.