



RHINO-RACK

Aerodynamic & Heavy Duty Roof Rack Systems

CONTROLLED

RLTFFD Rhino Heavy Duty - Fiat Ducato, Ram Promaster

Place these instructions in the vehicle's glove box after installation is complete.

Important: Please read these instructions carefully prior to installation. Please refer to your fitting instruction to ensure that the roof racks are installed in the correct locations. Check the contents of kit before commencing fitment and report any discrepancies

Maximum carrying capacity: 100kg

Parts List

Item	Part No.	Component Name	Qty
1	Z011	HEAVY DUTY RUBBER BUFFER TAPE	2
2	A023	HEAVY DUTY CROSSBAR (1650mm)	2
3	M002	HEAVY DUTY END CAP	4
4	B085	M6 x 40 BUTTON SECURITY SCREW	8
5	W004	M6 SPRING WASHERS	16
6	W003	M6 X 12.5MM FLAT WASHERS	16
7	B062	M6 X 20 BUTTON SECURITY SCREW	8
8	C343	FIAT DUCATO OUTER BRACKET	4
9	C344	FIAT DUCATO INNER BRACKET	4
10	N024	M10 CHANNEL NUT	4
11	M010	RLTF TRACK MOUNT LEG	4
12	W022	M10 X 38 X 2.5 FLAT WASHER	4
13	W021	M10 INTERNAL SHAKE PROOF WASHER	4
14	B071	M10 X 25 HEX BOLT	4
15	SECKEY-L	SECURITY KEY LONG	1
16	RR120	FITTING INSTRUCTION	1

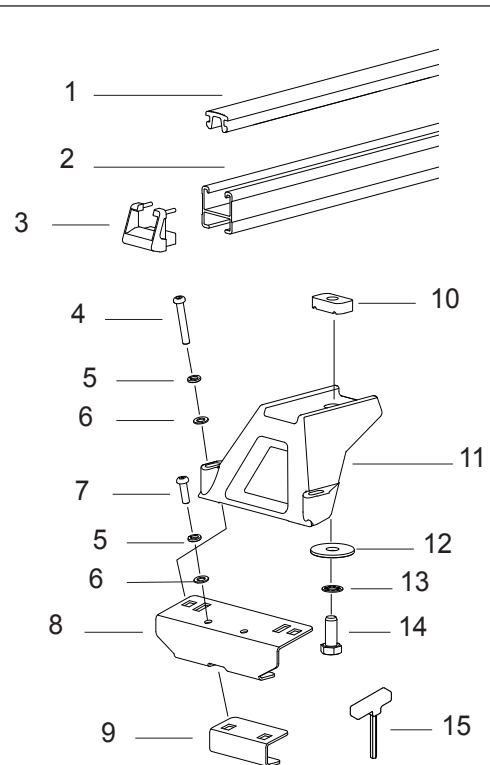

Layout

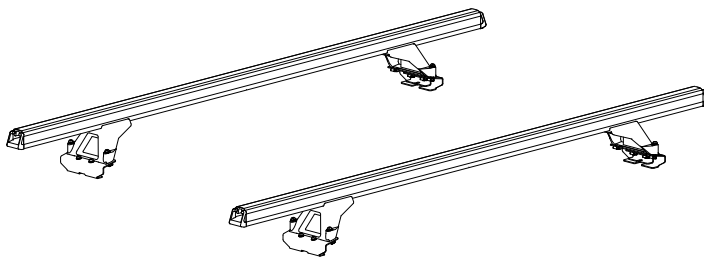

Care Instruction:

Wash and clean vehicle roof prior to fitting the Rhino Heavy Duty roof racks.

Tools Required

Allen key, provided in kit
5/8" spanner
Rubber mallet

Locate mounting points on roof (mushroom shaped pegs).

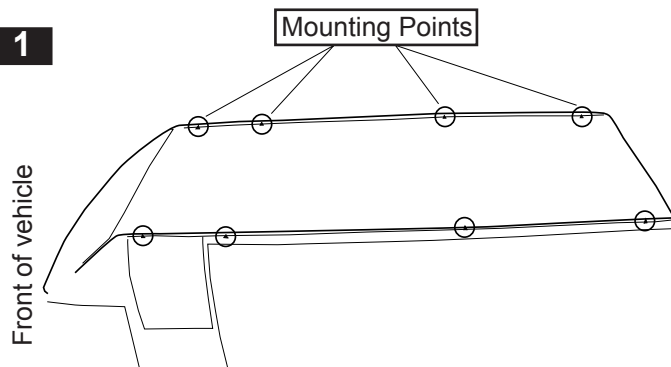

Hook the inner (smaller) bracket under the mounting point.

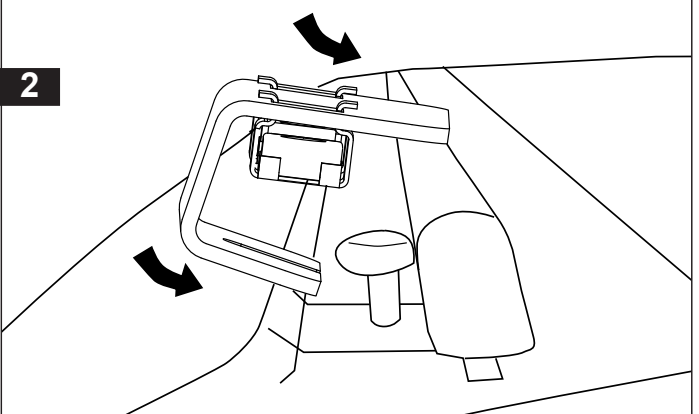

Now hook the outer (larger) bracket between the roof and the inner bracket.

3

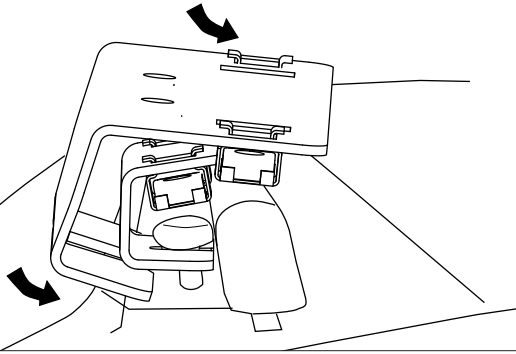

Assemble spring washer and flat washer onto the M6x20mm security bolt. Insert the bolt through the outer bracket and screw into inner bracket. Finger tighten brackets together, as some adjustment may be required later.

4

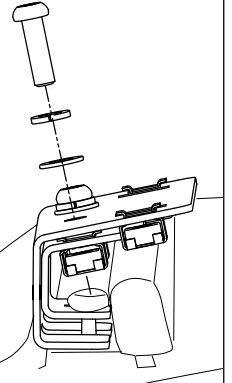

Place legs on mounting brackets.

5

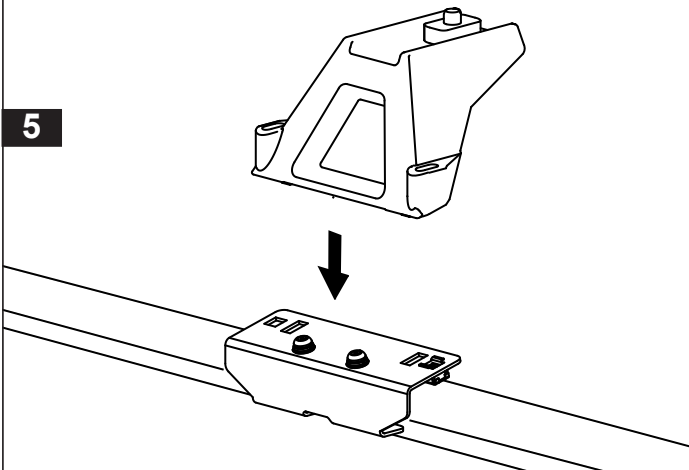

Place M6 spring washer then the M6 flat washer onto M6x40mm security screws. Insert the M6 screw through the legs and screw into the mounting bracket. Finger tighten as some adjustment may be required later.

6

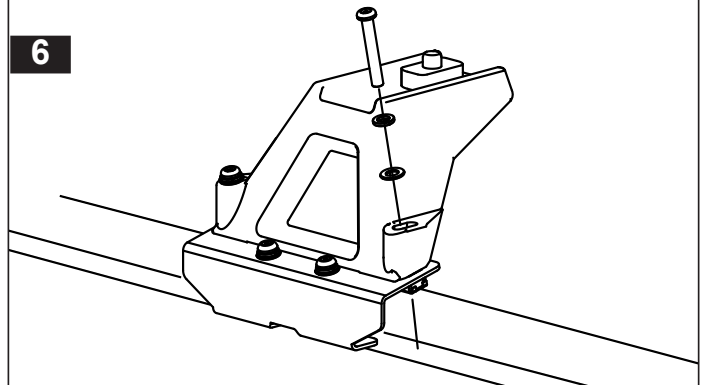

Place the crossbar onto the support legs. Push the crossbar attachment bolt up and turn the bolt so that the channel nut is located fully across the crossbar. Finger tighten the crossbar attachment bolts.

7

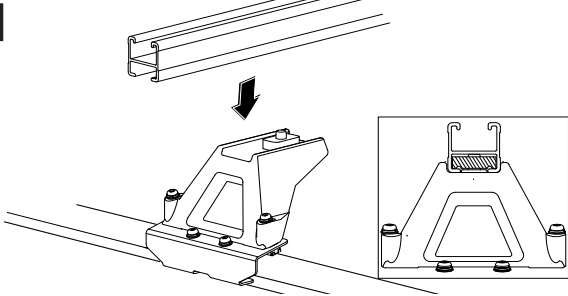

Check the channel nut is located across the crossbar.

Check the crossbar over hang (A) (B) is equal on both sides, re-adjust if required.

8

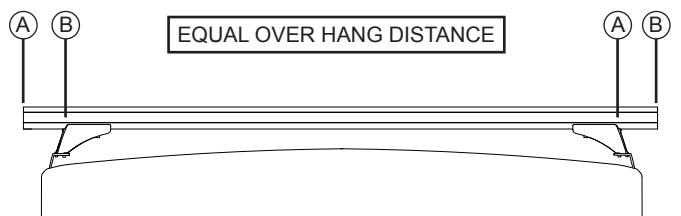

Push brackets in.

9

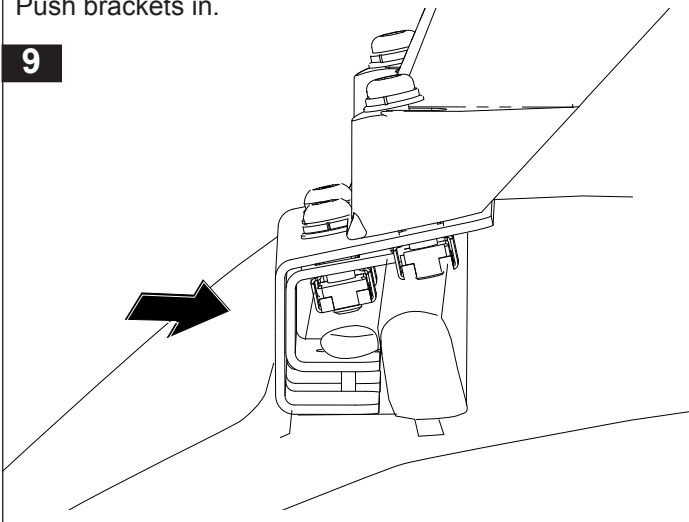

Tighten the crossbar attachment bolts. Recommended tightening torque 5N/m. DO NOT OVER TIGHTEN.

10

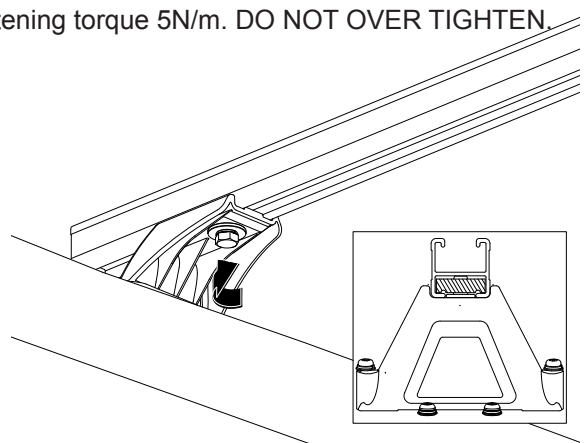

Check the channel nut is located across the crossbar.

Using the security allen key provided tighten legs to brackets then the brackets to each other until secure. Recommended tightening torque 3-4N/m. DO NOT OVER TIGHTEN.

11

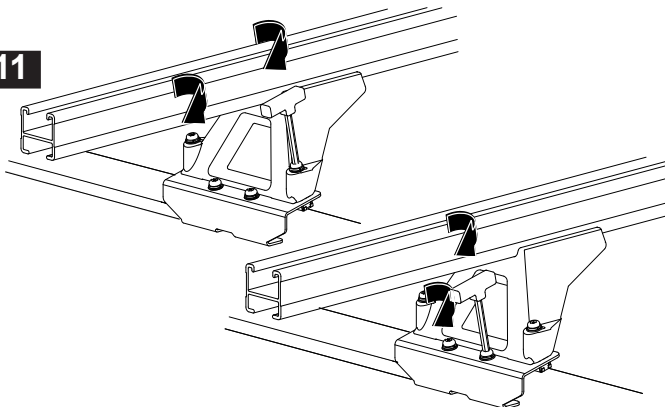

Insert the crossbar rubber buffer strip into the top of the crossbar. Insert end caps into the ends of the crossbar using rubber mallet. Check all attachment bolts and screws are secure after fitment.

12

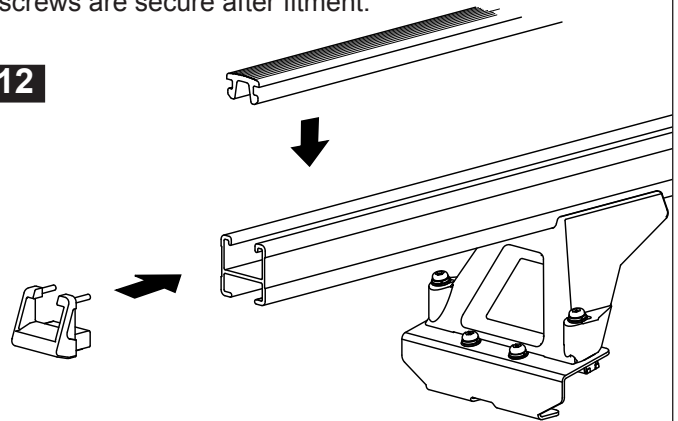

Important Information

RECOMMENDATIONS

Please refer to your fitting instruction to ensure that the Rhino Heavy Duty roof racks are installed in the correct locations.

The vehicles roof load rating may be less than the Rhino Heavy Duty roof rack load rating.

It is essential that all screw/bolt connections are checked after driving a short distance when you first install your Rhino-Rack.

Screw/bolt connections should be checked again at regular intervals (probably once a week is enough, depending on road conditions, usage, loads and distances travelled). You should also check the Roof Racks each time they are refitted.

Roof Racks and accessories should be cleaned and all screw threads should be lubricated at regular intervals. This will help avoid damage to your vehicles paint surface. Always clean the vehicle roof and the mounting brackets before fitting the roof bars.

Rhino-Rack offers a 3 year warranty to the original purchaser of Rhino-Roof Rack Systems and Accessories. Rhino-Rack cannot be held responsible for incorrect mounting of the Roof Racks or for usage that exceeds production tolerances.

Make sure to fasten the load securely. Please ensure that all loads are evenly distributed and that the centre of gravity is kept as low as possible.

USE ONLY NON-STRETCH FASTENING ROPES AND STRAPS

SENSITIVITY TO CROSSWINDS, BEHAVIOUR IN CURVES AND BRAKING

The handling of the car changes when you transport a load on the roof.

For safety reasons, we recommend you exercise extreme care when transporting wind resistant loads.

Special consideration must be taken into account when braking.

PLEASE REMOVE ROOF RACKS WHEN PUTTING VEHICLE THROUGH AUTOMATIC CAR WASH

LOAD RATINGS

Maximum permissible load is 100kg (include the weight of the roof bars, 5kg). When Roof Racks are to be used in off-road conditions, please build a safety factor of 1.5 into this load limit (67kg). Although the Roof Racks are tested and approved to AS1235-2000, Australian road conditions can be much more rigorous. Increasing the number of crossbars does not increase the vehicles maximum permissible roof loading.

NOTE FOR DEALERS AND FITTERS

It is your responsibility to ensure instructions are given to the end user or supplier.

Rhino-Rack
3 Pike Street, Rydalmere,
NSW 2116, Australia.
(Ph) (02) 9638 4744
(Fax) (02) 9638 4822

Document No: RR-120
Prepared By: Carl Tindall
Authorised By: Gary England

Issue No: 02
Issue Date: 23/03/2015

These instructions remain the property of Fetovu Pty Ltd T/as Rhino-Rack and may not be used or changed for any other purpose than intended.