

RHINO-RACK

RCP55-BK Dodge Nitro

- Important:**
- 1. Please refer to your fitting instruction to ensure that the roof racks are installed in the correct locations.
 - 2. Check the contents of kit before commencing fitment and report any discrepancies.
 - 3. Place these instructions in the vehicle's glove box after installation is complete.
 - 4. These instructions must be followed for warranty to be upheld.

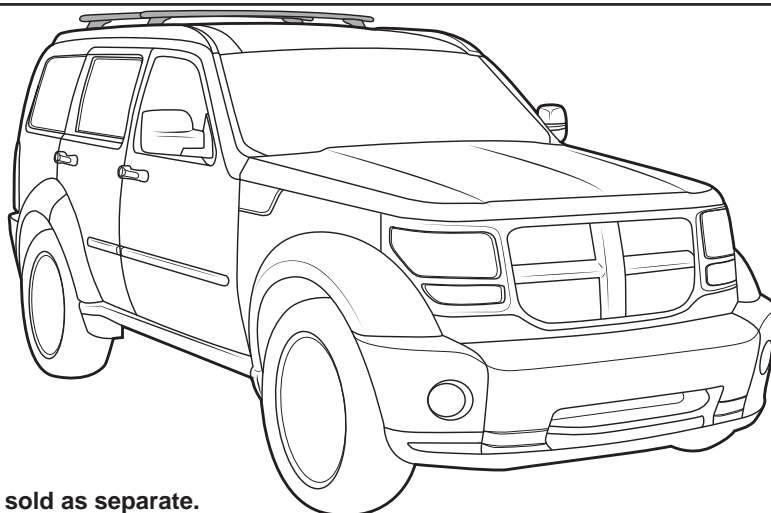

Note: Crossbars and legs sold as separate.

Important Information

On Road Cargo Allowance	Off Road Cargo Allowance	Roof Allowance	Rack Weight
63kg / 138lb	42kg / 92lbs	68kg / 150lbs	5kg / 11lb

Maximum carrying capacity: Two Crossbars; 68 kg (150 lbs) evenly distributed. Note: Be sure to check the Rhino-Rack website to see if you have the latest version of instructions before beginning.

Recommendations:

It is essential that all bolt connections be checked after driving a short distance when you first install your crossbars. Bolt connections should be checked again at regular intervals (once a week is enough, depending on road conditions, usage, loads and distances travelled). You should also check the crossbars each time they are re-fitted. Make sure to securely fasten any and all loads carried on your crossbars. Please ensure that all loads are evenly distributed over the crossbars and that the centre of gravity is kept as low as possible.

USE ONLY NON-STRETCH FASTENING ROPES OR STRAPS TO SECURE LOADS CARRIED.

Torque settings

Unless stated otherwise in these instructions, all fasteners should be set to the following torque settings - M5: 3-4Nm (2-3lbs/ft), M6: 4-5Nm (3-4lbs/ft), M8: 8-10Nm (6-7.5lbs/ft) and M10: 16-18Nm (12-13lbs/ft).

Sensitivity to crosswinds, behaviour in curves and braking.

The handling characteristics of the vehicle changes when you transport a load on the roof. For safety reasons, we recommend you exercise extreme care when transporting wind-resisting loads; Special consideration must be taken into account when braking.

Please remove crossbars when putting vehicle through an automatic car wash.

Load Ratings:

Maximum permissible load is 68 kg (150 lbs) for two crossbars include the weight of the crossbars 5 kg (11 lbs) . When crossbars are to be used in off-road conditions, please build a safety factor of 1.5 into this load limit for off-road use, two crossbars = 42 kg (92 lbs). Although the crossbars are tested and approved to AS1235-2000, road conditions can be much more rigorous. However, increasing the number of crossbars does not increase the vehicles maximum permissible roof loading.

Note for Dealers and Fitters:

It is your responsibility to ensure these instructions are given to the end user.

Rhino-Rack Australia Pty. Ltd.
3 Pike Street, Rydalmere,
NSW 2116, Australia.
(Ph) (02) 8846 1900
www.rhino-rack.com.au

Document No: R1229
Prepared By: Kayle Everett
Authorised By: Chris Murty

Fit Time: 30min
Issue No: 03
Issue Date: 19/04/2018

These instructions remain the property of Rhino-Rack Australia Pty. Ltd. and may not be used or changed for any other purpose than intended.



RCP55-BK Dodge Nitro

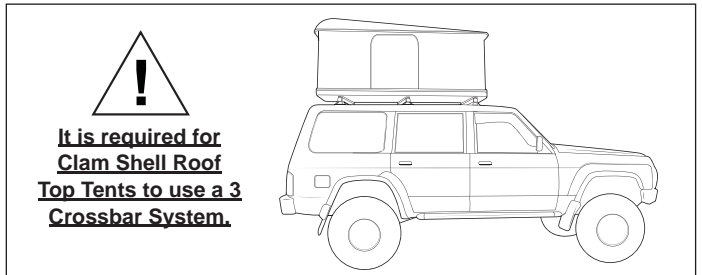
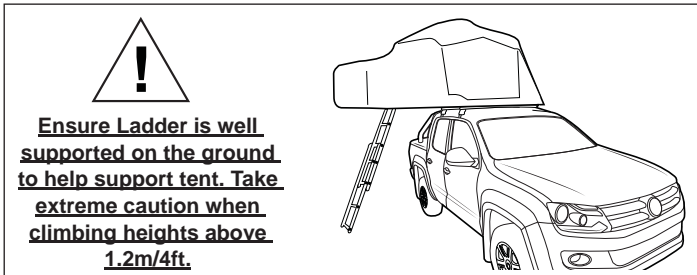
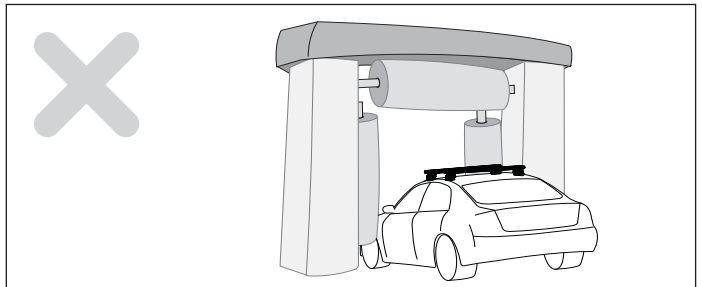
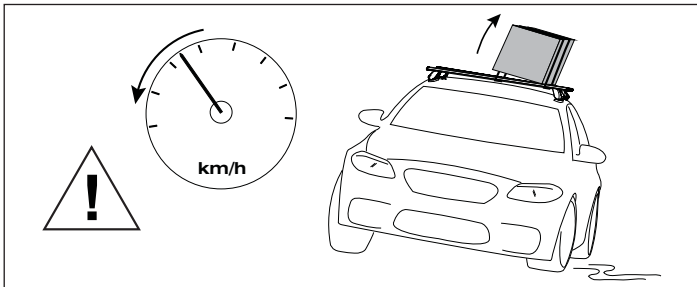
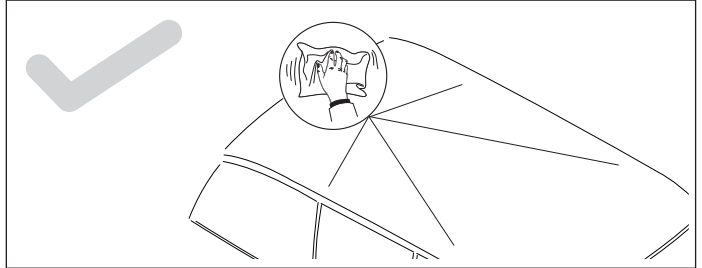
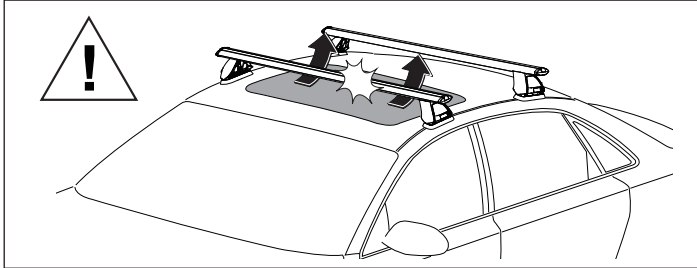
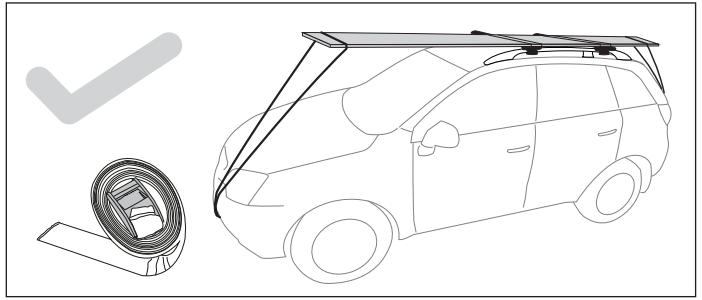
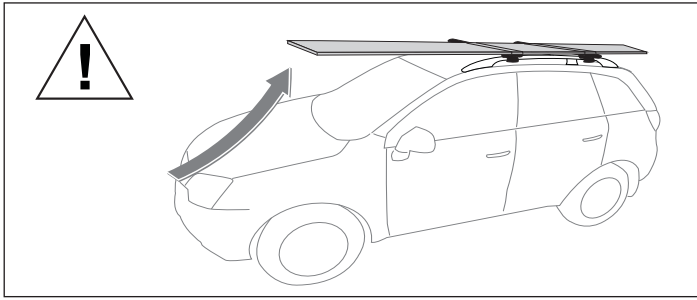

When these roof racks are to be used on a vehicle that is driven off sealed roads the maximum load rating must be divided by 1.5. Remember to subtract the weight of the roof racks to determine your maximum permissible load capacity.

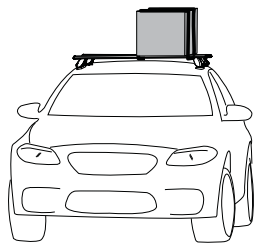

2 bars 68kg (138bs) load rating (Urban road) = 2 bars 42kg (92lbs) load rating (Off road)

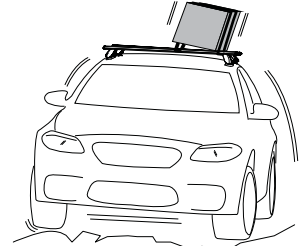

WARNING! Important Load Carrying Instructions

With utility vehicles, the cabin and the canopy move independently. Roof racks and vehicle can be damaged if the item transported is rigidly fixed at points on both the cabin and canopy. Instead, rigidly fix to either the cabin roof racks or the canopy roof racks.

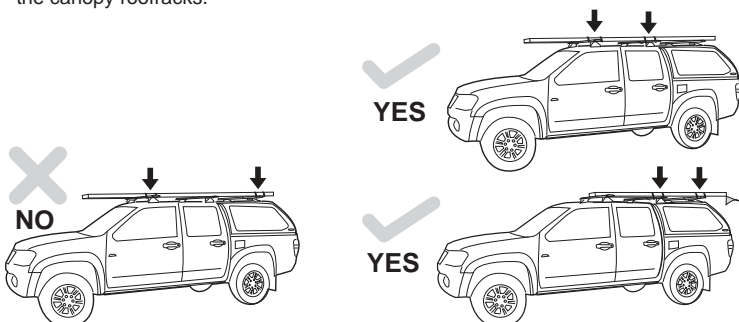

Paddle/ Surfboards should be fixed to the front of the vehicle.

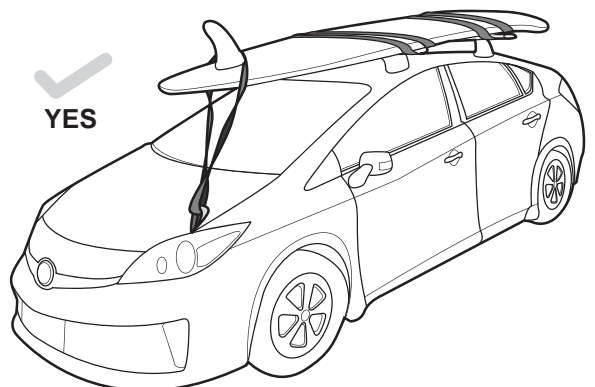



RCP55-BK Dodge Nitro

Parts List

Item	Components	Qty	Part No.
1	Dodge Nitro FL RR	2	CA1511
2	Dodge Nitro FR RL	2	CA1512
3	Nut ST/ST	4	N056
4	M6 x 16mm Flat Washer	4	W031
5	M6 x 20mm Hex Setscrew	4	B082
6	M6 Spring Washer	8	W004
7	M6 x 12.5mm Flat Washer	4	W003
8	Cover Plate	4	M126
9	Instructions	1	R1229

Tools Required: 10mm, 15mm socket wrench.

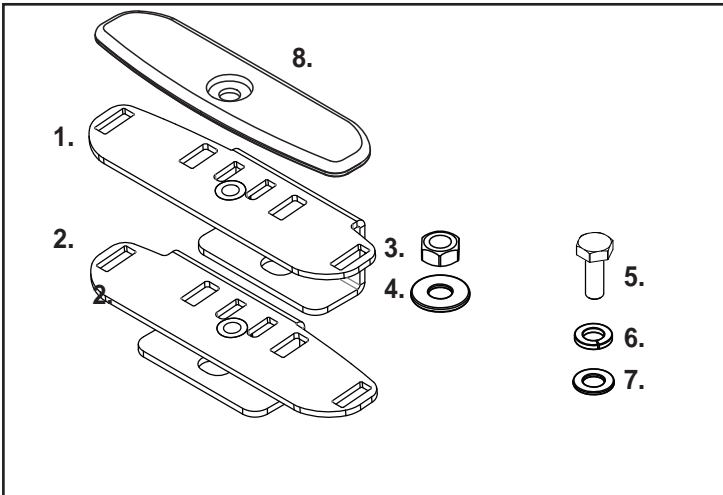

Instructions

1 Move to the roof of the vehicle and locate the mount points in the factory flush rail.

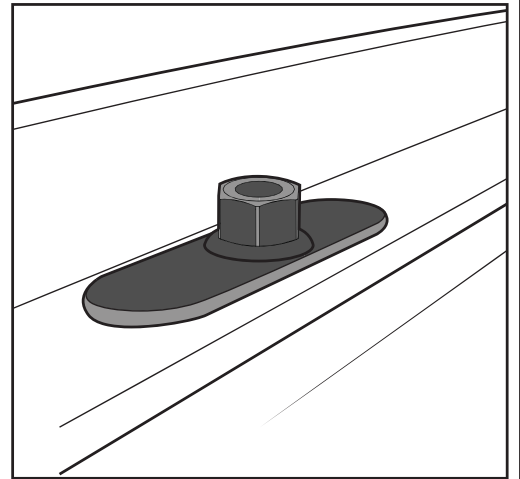
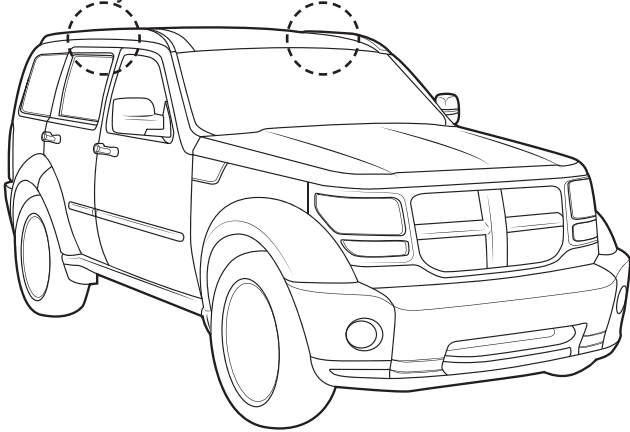

2 Using a 15mm socket, remove the plastic nuts on the mounts identified below (2nd and 4th from the front) . Store the nuts in a safe place.

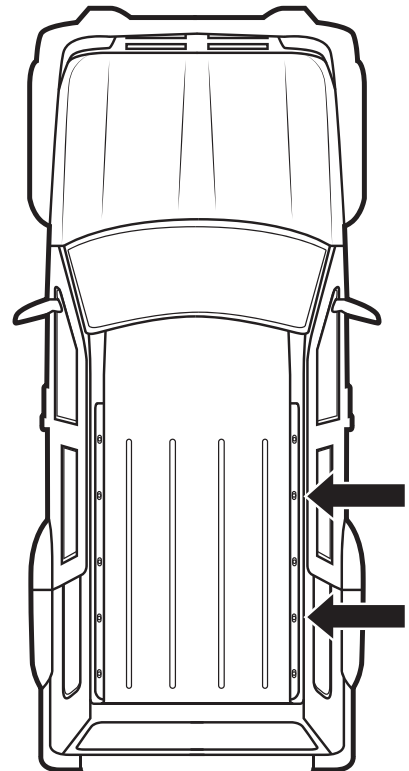
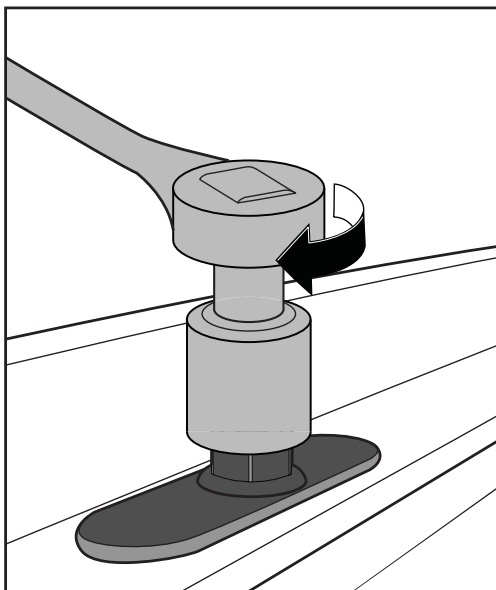



RCP55-BK Dodge Nitro

3 Place the brackets over the newly exposed studs in the roof.

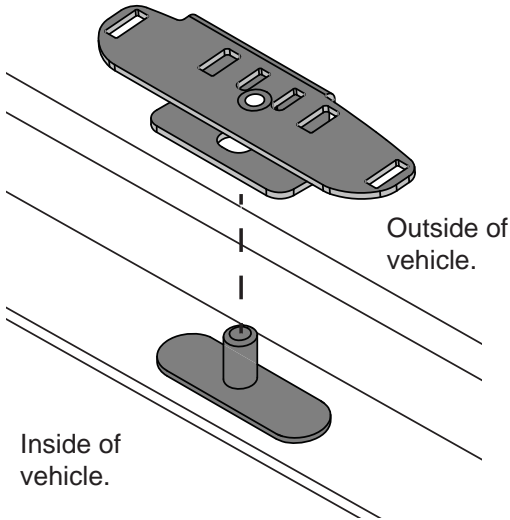

Side View: The bracket will slide over the stud.

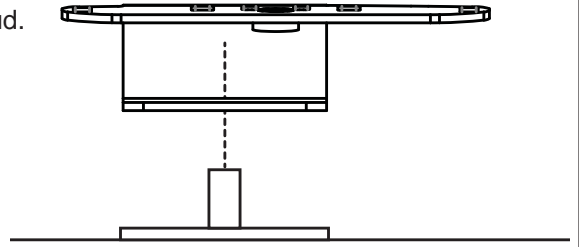

Orientation of brackets as shown. Longer side of brackets faces the centre of the vehicle.

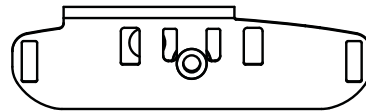

Rear

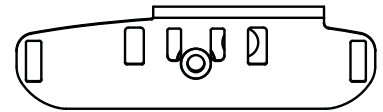

Front

4 Tighten the brackets in place with an M6 x 16mm flat washer, M6 spring washer and a nut. Tighten in place with 10mm wrench.

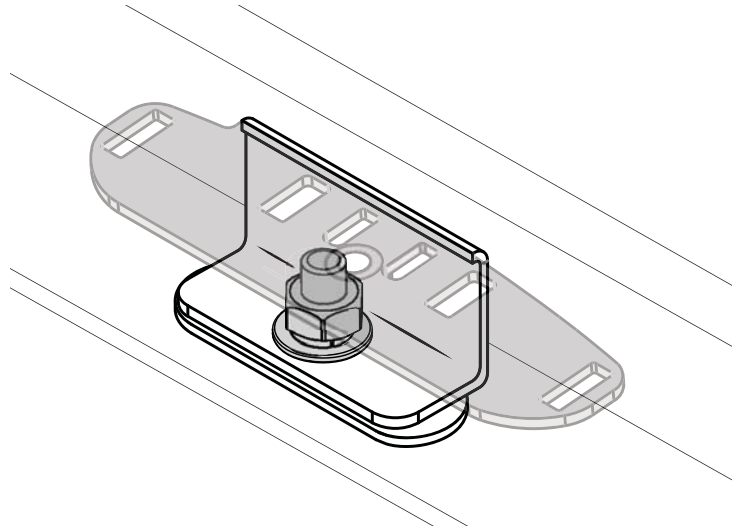
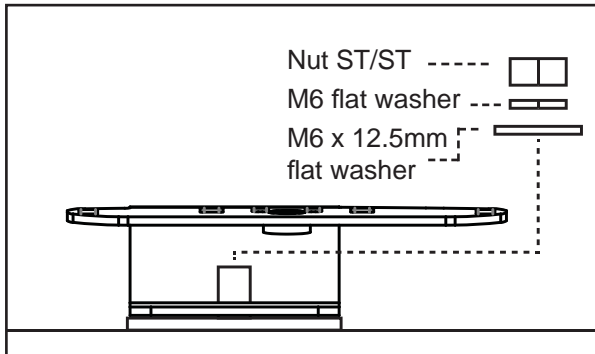

5 Use the M6 x 20mm hex setscrews, M6 spring washers and M6 x 16mm flat washers to attach the crossbars to the vehicle. Tighten with allen key provided. Check fixtures are secure before use.

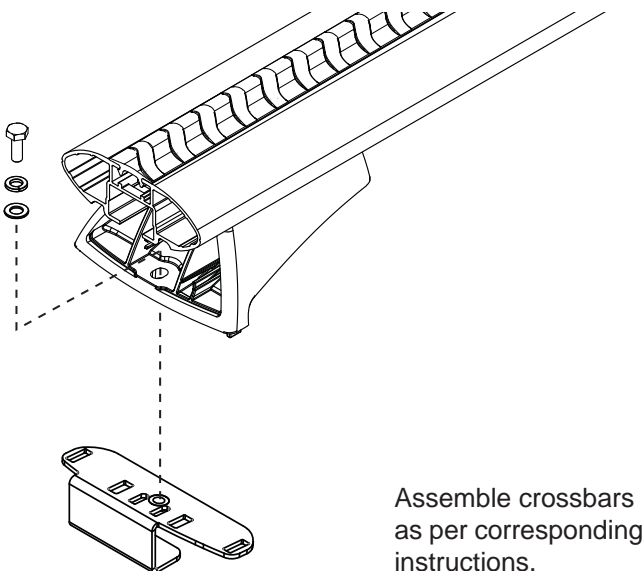

Assemble crossbars as per corresponding instructions.

6 When crossbars are not in use, remove and install the pad cover plates as shown.

