



RHINO-RACK

CONTROLLED

QMFK15

Please refer to 'Fit My Car' on the Rhino-Rack web site for comprehensive instructions on fitting racks to your vehicle.

RLT600 Parts as separate.

- Mark hole points through each bracket.
- Centre punch marked hole positions.
- Drill Ø5mm holes.
- Vacuum swarf and clean after drilling.
- Apply Cold Galvanising paint to holes.
- Apply Butyl patches concentric with each drilled hole.
- Locate the rivets through each bracket into drilled holes. Set all rivets.
- Fasten RLT600 base as per instructions.

Item	Component Name	Qty	Part No.
1	5mm Rivet	6	H008
2	Butyl Patch	6	CA1266
3	Quick Mount Bracket	2	CA1499
4	RLT600 Skirt High	2	M829
5	Instructions	1	R1014

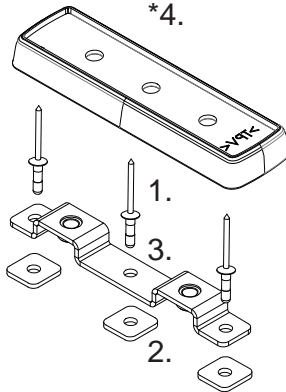

*Note: RLT600 skirt is optional and for aesthetic purposes only.

Issue: 02

Document No: R1014

Prepared by: Kayle Everett



RHINO-RACK

CONTROLLED

QMFK15

Please refer to 'Fit My Car' on the Rhino-Rack web site for comprehensive instructions on fitting racks to your vehicle.

RLT600 Parts as separate.

- Mark hole points through each bracket.
- Centre punch marked hole positions.
- Drill Ø5mm holes.
- Vacuum swarf and clean after drilling.
- Apply Cold Galvanising paint to holes.
- Apply Butyl patches concentric with each drilled hole.
- Locate the rivets through each bracket into drilled holes. Set all rivets.
- Fasten RLT600 base as per instructions.

Item	Component Name	Qty	Part No.
1	5mm Rivet	6	H008
2	Butyl Patch	6	CA1266
3	Quick Mount Bracket	2	CA1499
4	RLT600 Skirt High	2	M829
5	Instructions	1	R1014

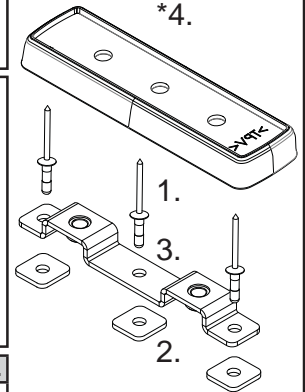

*Note: RLT600 skirt is optional and for aesthetic purposes only.

Issue: 02

Document No: R1014

Prepared by: Kayle Everett



RHINO-RACK

CONTROLLED

QMFK15

Please refer to 'Fit My Car' on the Rhino-Rack web site for comprehensive instructions on fitting racks to your vehicle.

RLT600 Parts as separate.

- Mark hole points through each bracket.
- Centre punch marked hole positions.
- Drill Ø5mm holes.
- Vacuum swarf and clean after drilling.
- Apply Cold Galvanising paint to holes.
- Apply Butyl patches concentric with each drilled hole.
- Locate the rivets through each bracket into drilled holes. Set all rivets.
- Fasten RLT600 base as per instructions.

Item	Component Name	Qty	Part No.
1	5mm Rivet	6	H008
2	Butyl Patch	6	CA1266
3	Quick Mount Bracket	2	CA1499
4	RLT600 Skirt High	2	M829
5	Instructions	1	R1014

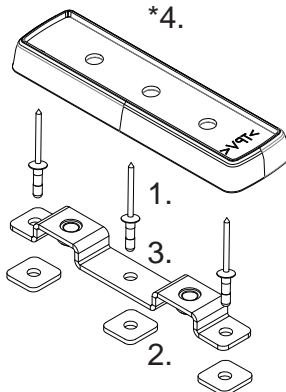

*Note: RLT600 skirt is optional and for aesthetic purposes only.

Issue: 02

Document No: R1014

Prepared by: Kayle Everett



RHINO-RACK

CONTROLLED

QMFK15

Please refer to 'Fit My Car' on the Rhino-Rack web site for comprehensive instructions on fitting racks to your vehicle.

RLT600 Parts as separate.

- Mark hole points through each bracket.
- Centre punch marked hole positions.
- Drill Ø5mm holes.
- Vacuum swarf and clean after drilling.
- Apply Cold Galvanising paint to holes.
- Apply Butyl patches concentric with each drilled hole.
- Locate the rivets through each bracket into drilled holes. Set all rivets.
- Fasten RLT600 base as per instructions.

Item	Component Name	Qty	Part No.
1	5mm Rivet	6	H008
2	Butyl Patch	6	CA1266
3	Quick Mount Bracket	2	CA1499
4	RLT600 Skirt High	2	M829
5	Instructions	1	R1014

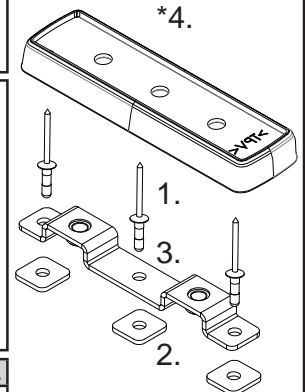

*Note: RLT600 skirt is optional and for aesthetic purposes only.

Issue: 02

Document No: R1014

Prepared by: Kayle Everett



RHINO-RACK

CONTROLLED

QMFK15

Please refer to 'Fit My Car' on the Rhino-Rack web site for comprehensive instructions on fitting racks to your vehicle.

RLT600 Parts as separate.

- Mark hole points through each bracket.
- Centre punch marked hole positions.
- Drill Ø5mm holes.
- Vacuum swarf and clean after drilling.
- Apply Cold Galvanising paint to holes.
- Apply Butyl patches concentric with each drilled hole.
- Locate the rivets through each bracket into drilled holes. Set all rivets.
- Fasten RLT600 base as per instructions.

Item	Component Name	Qty	Part No.
1	5mm Rivet	6	H008
2	Butyl Patch	6	CA1266
3	Quick Mount Bracket	2	CA1499
4	RLT600 Skirt High	2	M829
5	Instructions	1	R1014

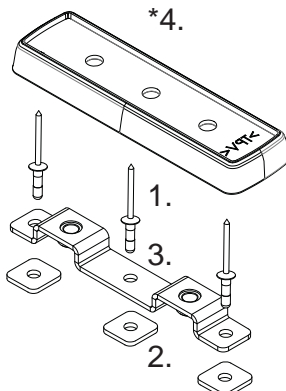

*Note: RLT600 skirt is optional and for aesthetic purposes only.

Issue: 02

Document No: R1014

Prepared by: Kayle Everett



RHINO-RACK

CONTROLLED

QMFK15

Please refer to 'Fit My Car' on the Rhino-Rack web site for comprehensive instructions on fitting racks to your vehicle.

RLT600 Parts as separate.

- Mark hole points through each bracket.
- Centre punch marked hole positions.
- Drill Ø5mm holes.
- Vacuum swarf and clean after drilling.
- Apply Cold Galvanising paint to holes.
- Apply Butyl patches concentric with each drilled hole.
- Locate the rivets through each bracket into drilled holes. Set all rivets.
- Fasten RLT600 base as per instructions.

Item	Component Name	Qty	Part No.
1	5mm Rivet	6	H008
2	Butyl Patch	6	CA1266
3	Quick Mount Bracket	2	CA1499
4	RLT600 Skirt High	2	M829
5	Instructions	1	R1014

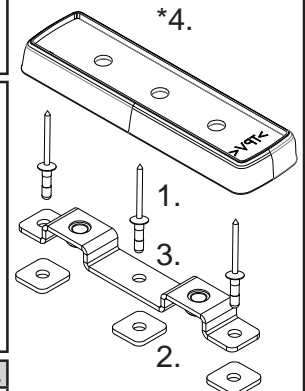

*Note: RLT600 skirt is optional and for aesthetic purposes only.

Issue: 02

Document No: R1014

Prepared by: Kayle Everett