

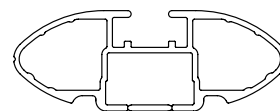

CROSSBAR IDENTIFICATION

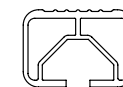





VA crossbar

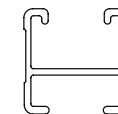

EURO crossbar

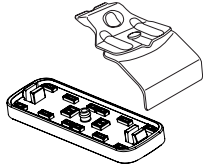
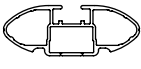

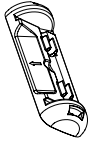
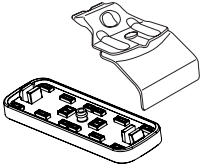
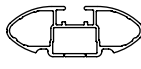
HD crossbar

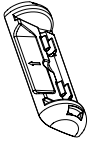
			FRONT CROSSBAR						REAR CROSSBAR					
														
Vehicle	Date	Crossbar	Front Right Pad/Clamp	Front Left Pad/Clamp	Measurement strip length per side	Measurement strip length per side	Measurement Distance (x)	Foot plate arrow direction	Rear Right Pad/Clamp	Rear Left Pad/Clamp	Measurement strip length per side	Measurement strip length per side	Measurement Distance (x)	Foot plate arrow direction
KIA Optima 4dr sedan JF 4th Gen. (Panoramic Glass Roof must not be operated with Vortex 2500 RS roof rack installed)	16-	1260mm	M435 SUB0146	M436 SUB0146	180mm	67mm	1008mm / 39,11/16"	OUT	M368 SUB0176	M368 SUB0176	157mm	44mm	962mm / 37,7/8"	OUT
			Pad Arrow Forward						Pad Arrow Out					



Rhino-Rack 2500 Series - DK436 instruction

CONTROLLED

Measurement A: CENTRE of door jamb to CENTRE arrow of leg foot plate.

Measurement B: CENTRE of Front leg foot plate arrow to CENTRE of Rear leg foot plate arrow.

Carrying capacity: Roof rack is rated to 75kg. Please refer to manufacturers handbook for your vehicles maximum roof load capacity. Always use the lower of the two figures.

If your vehicle is not listed on this fitting instruction please refer to your countries Rhino-Rack web site for the latest information.

Direction of Pad Arrow and Foot Plate Arrow

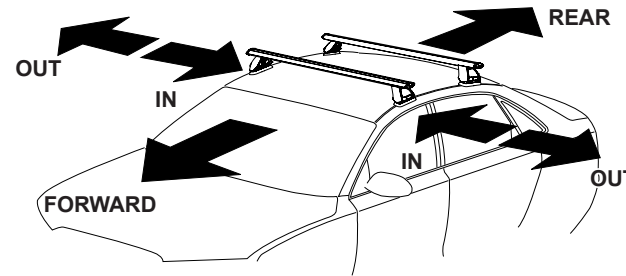

FRONT

REAR

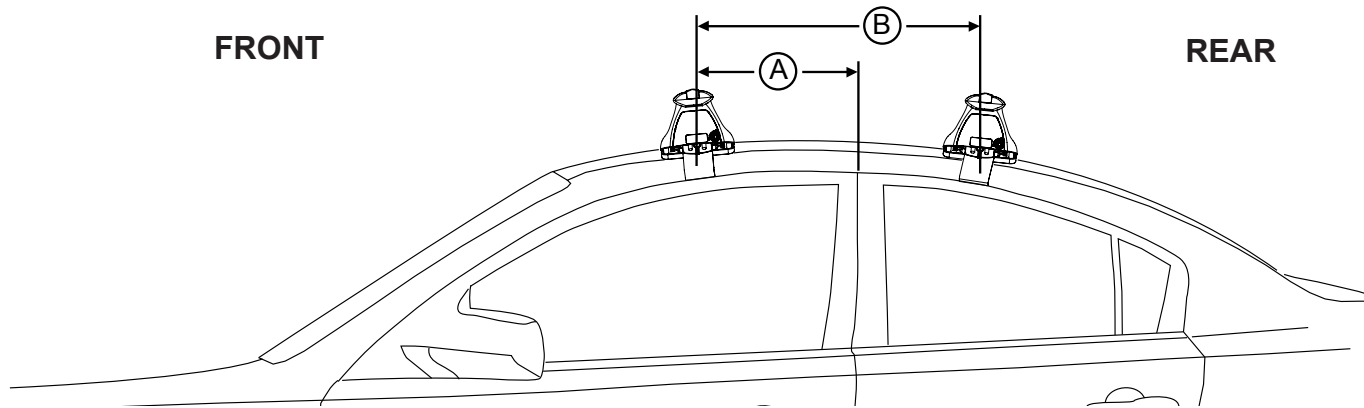

VEHICLE	Date	Measurement A	Measurement B	Load Rating (includes racks 5kg/ 11lbs)
KIA Optima 4dr sedan JF 4th Gen. (Panoramic Glass Roof must not be operated with Vortex 2500 RS roof rack installed)	16-	320mm / 12,39/64"	750mm / 29,17/32"	75kg / 165lbs