

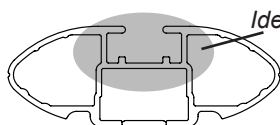

DK330 Rhino-Rack VA, Aero, Euro & HD crossbar instruction

IDENTIFICATION CHART



VA crossbar

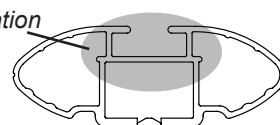

AERO crossbar

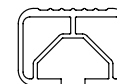

EURO crossbar

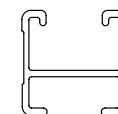

HD crossbar

Vehicle	Date	Crossbar	Front					Rear					
			Right Pad/ Clamp	Left Pad/ Clamp	Measurement strip length per side	Measurement strip length per side	Measurement Distance (x)	Foot plate arrow direction	Right Pad/ Clamp	Left Pad/ Clamp	Measurement strip length per side	Measurement strip length per side	Measurement Distance (x)
Holden Colorado Single cab RG	06/12-	1260mm	M506 SUB0247	M505 SUB0247	179mm	66mm	1006mm / 39,39/64"	OUT	N/A	N/A	N/A	N/A	N/A
			Arrow OUT						N/A				
Holden Colorado Space cab RG	06/12-	1260mm	M506 SUB0247	M505 SUB0247	180mm	67mm	1008mm / 39,11/16"	OUT	M368 SUB0247	175mm	62mm	998mm / 39,19/64"	OUT
			Arrow OUT						Arrow OUT				
Holden Colorado Space cab RG (single Centre bar)	06/12-	1260mm	M506 SUB0247	M505 SUB0247	177mm	64mm	1002mm / 39,29/64"	OUT	N/A	N/A	N/A	N/A	N/A
			Arrow OUT						N/A				
Holden Colorado Crew cab RG	06/12-	1260mm	M506 SUB0247	M505 SUB0247	178mm	65mm	1004mm / 39,17/32"	OUT	M368 SUB0247	172mm	59mm	992mm / 39,1/16"	OUT
			Arrow OUT						Arrow OUT				
Chevrolet S10 Regular cab	2013-	1260mm	M506 SUB0247	M505 SUB0247	179mm	66mm	1006mm / 39,39/64"	OUT	N/A	N/A	N/A	N/A	N/A
			Arrow OUT						N/A				



DK330 Rhino-Rack VA, Aero, Euro & HD crossbar instruction

IDENTIFICATION CHART

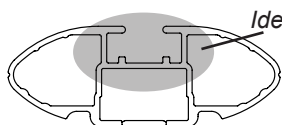

VA crossbar

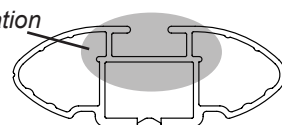

AERO crossbar

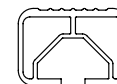

EURO crossbar

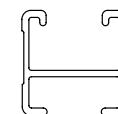

HD crossbar

Vehicle	Date	Crossbar	Front Side					Rear Side					
			Front Right Pad/ Clamp	Front Left Pad/ Clamp	Measurement strip length per side	Measurement strip length per side	Measurement Distance (x)	Foot plate arrow direction	Rear Right Pad/ Clamp	Rear Left Pad/ Clamp	Measurement strip length per side	Measurement strip length per side	Measurement Distance (x)
Chevrolet S10 Extended cab	2013-	1260mm	M506 SUB0247	M505 SUB0247	180mm	67mm	1008mm / 39,11/16"	OUT	M368 SUB0247	175mm	62mm	998mm / 39,19/64"	OUT
			Arrow OUT						Arrow OUT				
Chevrolet S10 Extended cab (single Center bar)	2013-	1260mm	M506 SUB0247	M505 SUB0247	177mm	64mm	1002mm / 39,29/64"	OUT	N/A	N/A	N/A	N/A	N/A
			Arrow OUT						N/A				
Chevrolet S10 Double cab	2013-	1260mm	M506 SUB0247	M505 SUB0247	178mm	65mm	1004mm / 39,17/32"	OUT	M368 SUB0247	172mm	59mm	992mm / 39,1/16"	OUT
			Arrow OUT						Arrow OUT				
Chevrolet Colorado Regular cab	2013-	1260mm	M506 SUB0247	M505 SUB0247	179mm	66mm	1006mm / 39,39/64"	OUT	N/A	N/A	N/A	N/A	N/A
			Arrow OUT						N/A				
Chevrolet Colorado Extended cab	2013-	1260mm	M506 SUB0247	M505 SUB0247	180mm	67mm	1008mm / 39,11/16"	OUT	M368 SUB0247	175mm	62mm	998mm / 39,19/64"	OUT
			Arrow OUT						Arrow OUT				



DK330 Rhino-Rack VA, Aero, Euro & HD crossbar instruction

IDENTIFICATION CHART

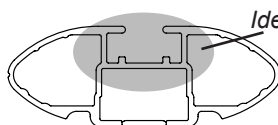

VA crossbar

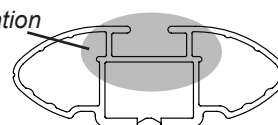

AERO crossbar



EURO crossbar

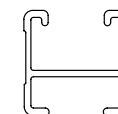

HD crossbar

Vehicle	Date	Crossbar	Front					Rear					
			Right Pad/ Clamp	Left Pad/ Clamp	Measurement strip length per side	Measurement strip length per side	Measurement Distance (x)	Foot plate arrow direction	Right Pad/ Clamp	Left Pad/ Clamp	Measurement strip length per side	Measurement strip length per side	Measurement Distance (x)
Chevrolet Colorado Extended cab (single Center bar)	2013-	1260mm	M506 SUB0247	M505 SUB0247	177mm	64mm	1002mm / 39,29/64"	OUT	N/A	N/A	N/A	N/A	N/A
			Arrow OUT						N/A				
Chevrolet Colorado Crew cab	2013-	1260mm	M506 SUB0247	M505 SUB0247	178mm	65mm	1004mm / 39,17/32"	OUT	M368 SUB0247	172mm	59mm	992mm / 39,1/16"	OUT
			Arrow OUT						Arrow OUT				
Isuzu DMAX Single cab TF	06/12-	1260mm	M506 SUB0247	M505 SUB0247	179mm	66mm	1006mm / 39,39/64"	OUT	N/A	N/A	N/A	N/A	N/A
			Arrow OUT						N/A				
Isuzu DMAX Space cab TF	06/12-	1260mm	M506 SUB0247	M505 SUB0247	180mm	67mm	1008mm / 39,11/16"	OUT	M368 SUB0247	175mm	62mm	998mm / 39,19/64"	OUT
			Arrow OUT						Arrow OUT				
Isuzu DMAX Space cab TF (single Centre bar)	06/12-	1260mm	M506 SUB0247	M505 SUB0247	177mm	64mm	1002mm / 39,29/64"	OUT	N/A	N/A	N/A	N/A	N/A
			Arrow OUT						N/A				



DK330 Rhino-Rack VA, Aero, Euro & HD crossbar instruction

IDENTIFICATION CHART

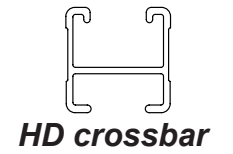
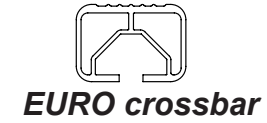
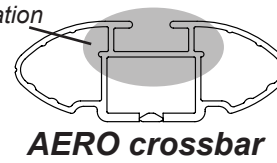
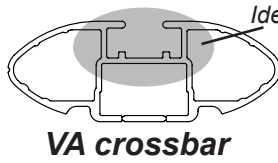

Vehicle	Date	Crossbar	Front					Rear					
			Right Pad/ Clamp	Left Pad/ Clamp	strip length per side	strip length per side	Distance (x)	Foot plate arrow direction	Right Pad/ Clamp	Left Pad/ Clamp	strip length per side	strip length per side	Distance (x)
Isuzu DMAX Crew cab TF	06/12-	1260mm	M506 SUB0247	M505 SUB0247	178mm	65mm	1004mm / 39,17/32"	OUT	M368 SUB0247	172mm	59mm	992mm / 39,1/16"	OUT
			Arrow OUT						Arrow OUT				



DK330 Rhino-Rack VA, Aero, Euro & HD crossbar instruction

Measurement A: CENTRE of door jamb to CENTRE arrow of leg foot plate.

Measurement B: CENTRE of Front leg foot plate arrow to CENTRE of Rear leg foot plate arrow.

Carrying capacity: Roof rack is rated to 75kg. Please refer to manufacturers handbook for your vehicles maximum roof load capacity. Always use the lower of the two figures.

If your vehicle is not listed on this fitting instruction please refer to your countries Rhino-Rack web site for the latest information.

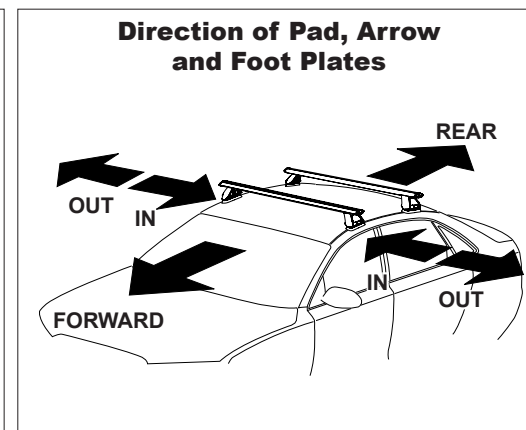
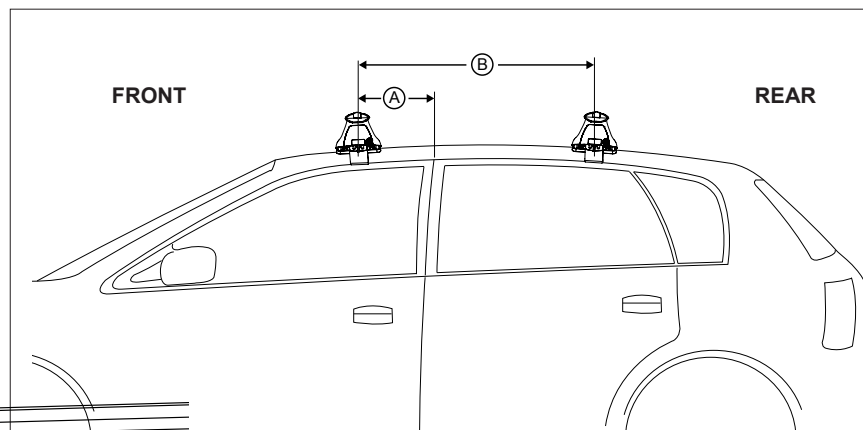
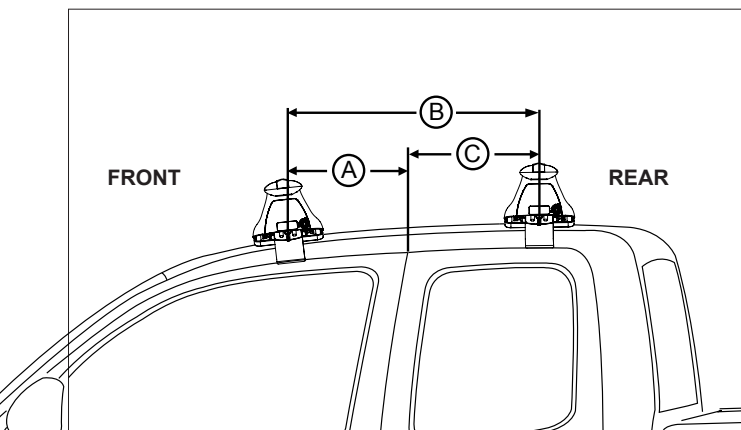

VEHICLE	Date	Measurement A	Measurement B	Measurement C	Load Rating (includes racks 5kg/ 11lbs)
Holden Colorado Single Cab RG	06/12-	230mm / 9,1/16"	-	-	35kg / 77lbs
Holden Colorado Space Cab RG	06/12-	320mm / 12,19/32"	700mm / 27,9/16" (double crossbar)	380mm / 14,31/32" (single crossbar)	35kg / 77lbs (single crossbar) 75kg / 165lbs (double crossbar)
Holden Colorado Space Cab RG (single centre bar)	06/12-	30mm / 1,3/16"	-	-	35kg / 77lbs
Holden Colorado Crew Cab RG	06/12-	250mm / 9,27/32"	700mm / 27,9/16" (double crossbar)	450mm / 17,23/32" (single crossbar)	35kg / 77lbs (single crossbar) 75kg / 165lbs (double crossbar)
Chevrolet S10/Colorado Single Cab	2013-	230mm / 9,1/16"	-	-	35kg / 77lbs
Chevrolet S10/Colorado Extended Cab	2013-	320mm / 12,19/32"	700mm / 27,9/16" (double crossbar)	380mm / 14,31/32" (single crossbar)	35kg / 77lbs (single crossbar) 75kg / 165lbs (double crossbar)



DK330 Rhino-Rack VA, Aero, Euro & HD crossbar instruction

Measurement A: CENTRE of door jamb to CENTRE arrow of leg foot plate.

Measurement B: CENTRE of Front leg foot plate arrow to CENTRE of Rear leg foot plate arrow.

Carrying capacity: Roof rack is rated to 75kg. Please refer to manufacturers handbook for your vehicles maximum roof load capacity. Always use the lower of the two figures.

If your vehicle is not listed on this fitting instruction please refer to your countries Rhino-Rack web site for the latest information.

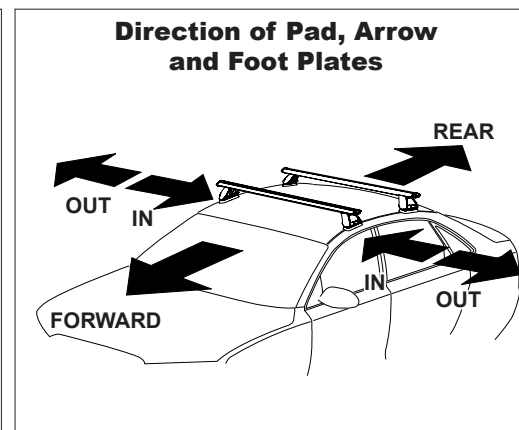
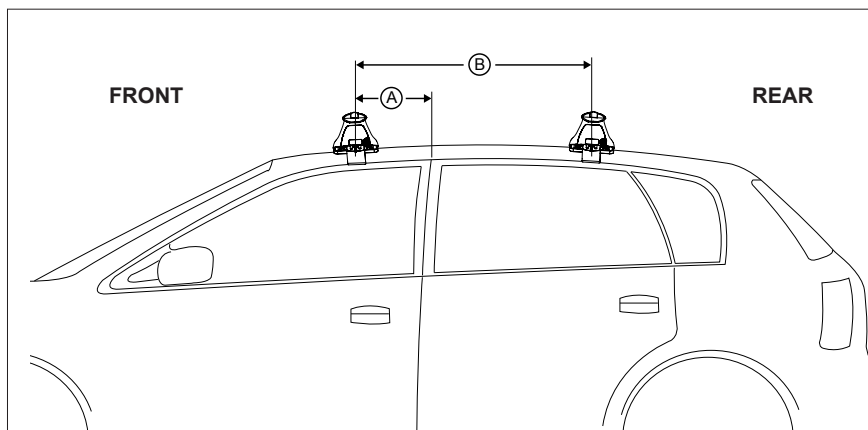

VEHICLE	Date	Measurement A	Measurement B	Measurement C	Load Rating (includes racks 5kg/11lbs)
Chevrolet S10/Colorado Extended Cab (single center bar)	2013-	30mm / 1,3/16"	-	-	35kg / 77lbs
Chevrolet S10/Colorado Crew Cab RG	2013-	250mm / 9,27/32"	700mm / 27,9/16" (double crossbar)	450mm / 17,23/32" (single crossbar)	35kg / 77lbs (single crossbar) 75kg / 165lbs (double crossbar)
Isuzu DMAX Single cab TF	06/12-	230mm / 9,1/16"	-	-	35kg / 77lbs
Isuzu DMAX Space cab TF	06/12-	320mm / 12,19/32"	700mm / 27,9/16" (double crossbar)	380mm / 14,31/32" (single crossbar)	35kg / 77lbs (single crossbar) 75kg / 165lbs (double crossbar)
Isuzu DMAX Space cab TF (single center bar)	06/12-	30mm / 1,3/16"	-	-	35kg / 77lbs
Isuzu DMAX Crew cab TF	06/12-	250mm / 9,27/32"	700mm / 27,9/16" (double crossbar)	450mm / 17,23/32" (single crossbar)	35kg / 77lbs (single crossbar) 75kg / 165lbs (double crossbar)