

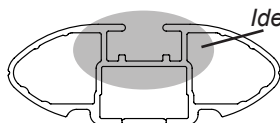

# DK294 Rhino-Rack VA, Aero, Euro & HD crossbar instruction

## IDENTIFICATION CHART



VA crossbar

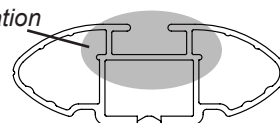

AERO crossbar

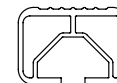

EURO crossbar

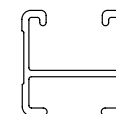

HD crossbar

Vehicle	Date	Crossbar	Front					Rear										
			Right Pad/ Clamp	Left Pad/ Clamp	Measurement strip length per side	Measurement strip length per side	Measurement Distance ( x )	Foot plate arrow direction	Right Pad/ Clamp	Left Pad/ Clamp	Measurement strip length per side	Measurement strip length per side	Measurement Distance ( x )	Foot plate arrow direction				
Ford Ranger PX Double Cab	2011-	1375mm	M367 SUB0146	VA	133mm	AERO EURO	78mm	HD	1029mm	OUT	M367 SUB0145	VA	122mm	AERO EURO	67mm	HD	1007mm	OUT
			Arrow FORWARD								Arrow FORWARD							
Ford Ranger PX Double Cab (single FRONT bar)	2011-	1375mm	M367 SUB0146	VA	133mm	AERO EURO	78mm	HD	1029mm	OUT	N/A	VA	N/A	AERO EURO	67mm	HD	1007mm	OUT
			Arrow FORWARD								N/A							
Ford Ranger PX Double Cab (single REAR bar)	2011-	N/A	N/A	VA	133mm	AERO EURO	78mm	HD	1029mm	OUT	M367 SUB0145	VA	122mm	AERO EURO	67mm	HD	1007mm	OUT
			Arrow FORWARD								N/A							
Mazda BT50 Dual Cab	2011-	1375mm	M367 SUB0146	VA	133mm	AERO EURO	78mm	HD	1029mm	OUT	M367 SUB0145	VA	122mm	AERO EURO	67mm	HD	1007mm	OUT
			Arrow FORWARD								Arrow FORWARD							
Mazda BT50 Dual Cab (single FRONT bar)	2011-	1375mm	M367 SUB0146	VA	133mm	AERO EURO	78mm	HD	1029mm	OUT	N/A	VA	N/A	AERO EURO	67mm	HD	1007mm	OUT
			Arrow FORWARD								N/A							



# DK294 Rhino-Rack VA, Aero, Euro & HD crossbar instruction

## IDENTIFICATION CHART

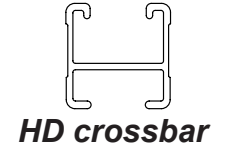
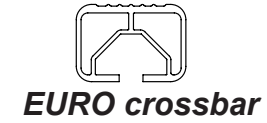
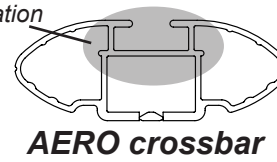
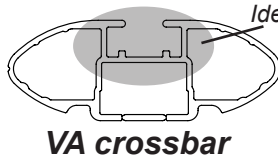

Vehicle	Date	Crossbar	Front					Rear						
			Right Pad/ Clamp	Left Pad/ Clamp	Measurement strip length per side	Measurement strip length per side	Measurement Distance ( x )	Foot plate arrow direction	Right Pad/ Clamp	Left Pad/ Clamp	Measurement strip length per side	Measurement strip length per side	Measurement Distance ( x )	Foot plate arrow direction
Mazda BT50 Dual Cab (single REAR bar)	2011-		N/A		N/A	N/A	N/A	N/A	M505 SUB0256	M506 SUB0256	122mm	67mm	1007mm	OUT
			N/A						Arrow FORWARD					



# DK294 Rhino-Rack VA, Aero, Euro & HD crossbar instruction

**Measurement A:** CENTRE of door jamb to CENTRE arrow of leg foot plate.

**Measurement B:** CENTRE of Front leg foot plate arrow to CENTRE of Rear leg foot plate arrow.

**Carrying capacity:** Roof rack is rated to 75kg. Please refer to manufacturers handbook for your vehicles maximum roof load capacity. Always use the lower of the two figures.

If your vehicle is not listed on this fitting instruction please refer to your countries Rhino-Rack web site for the latest information.

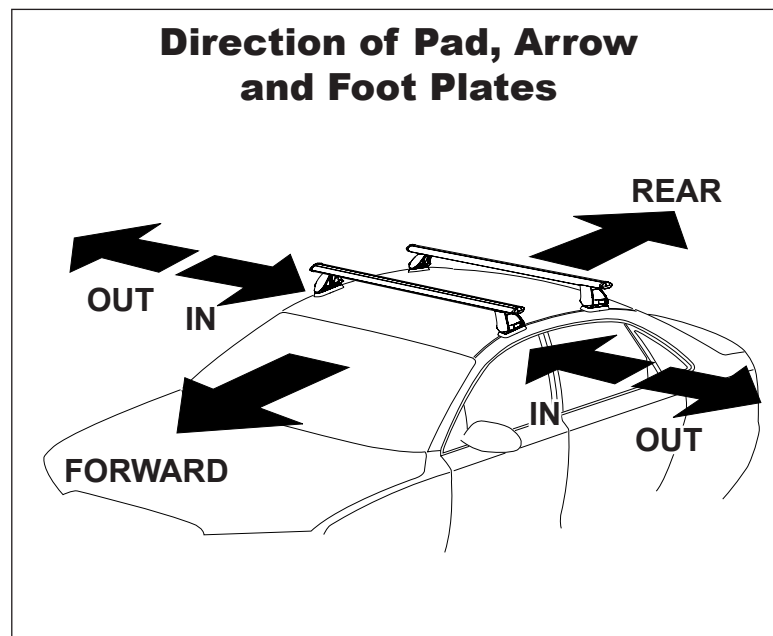
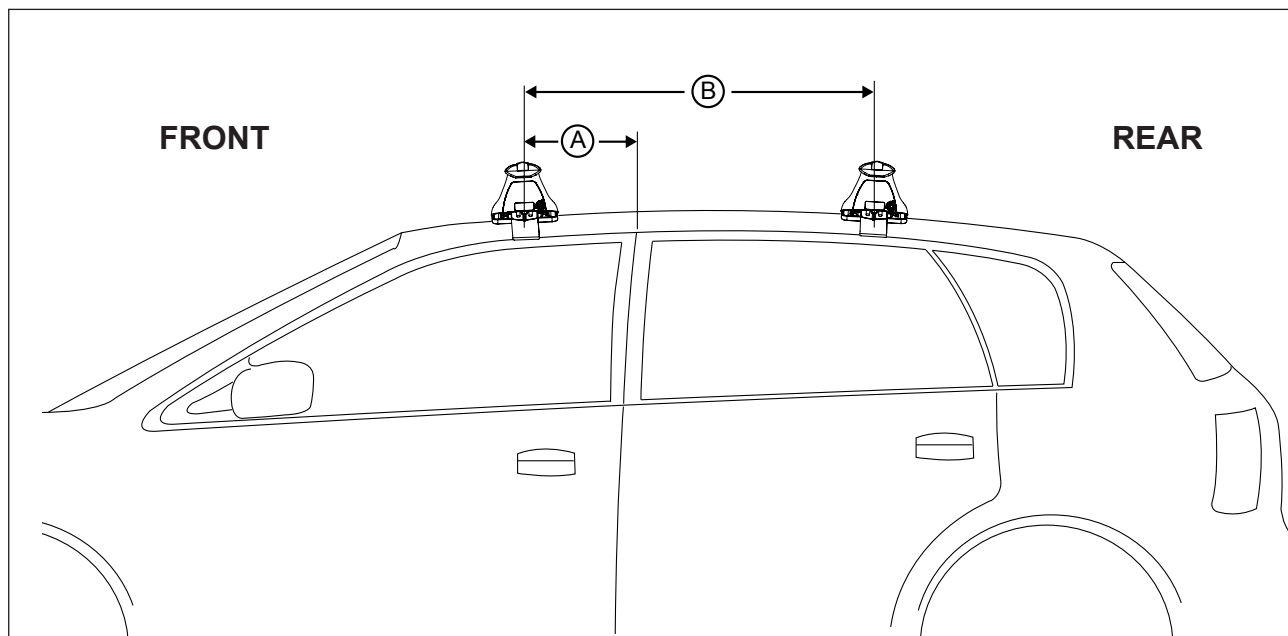

VEHICLE	Date	Measurement A	Measurement B	Measurement C	Load Rating (includes racks 5kg/ 11lbs)
Ford Ranger PX Double Cab	2011-	200mm / 7,7/8"	800mm / 31,1/2"	N/A	75kg / 165lbs
Ford Ranger PX Double Cab (single FRONT bar)	2011-	200mm / 7,7/8"	N/A	N/A	35kg / 77lbs
Ford Ranger PX Double Cab (single REAR bar)	2011-	N/A	N/A	600mm / 23,5/8"	35kg / 77lbs
Mazda BT50 Dual Cab	2011-	200mm / 7,7/8"	800mm / 31,1/2"	N/A	75kg / 165lbs
Mazda BT50 Dual Cab (single FRONT bar)	2011-	200mm / 7,7/8"	N/A	N/A	35kg / 77lbs
Mazda BT50 Dual Cab (single REAR bar)	2011-	N/A	N/A	600mm / 23,5/8"	35kg / 77lbs