



DK284 Rhino-Rack VA, Aero, Euro & HD crossbar instruction

IDENTIFICATION CHART



VA crossbar

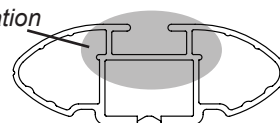

AERO crossbar



EURO crossbar

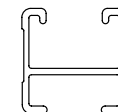

HD crossbar

Vehicle	Date	Crossbar	Front					Rear				
			Right Pad/ Clamp	Left Pad/ Clamp	Measurement strip length per side	Measurement strip length per side	Measurement Distance (x)	Foot plate arrow direction	Right Pad/ Clamp	Left Pad/ Clamp	Measurement strip length per side	Measurement strip length per side
Mitsubishi Challenger	12/09-	1260mm	M366 SUB0145	178mm	65mm	1004mm / 39,17/32"	OUT	M366 SUB0256	171mm	58mm	990mm / 38,31/32"	OUT
			Arrow FORWARD					Arrow FORWARD				
Mitsubishi Pajero Sport	10-	1260mm	M366 SUB0145	178mm	65mm	1004mm / 39,17/32"	OUT	M366 SUB0256	171mm	58mm	990mm / 38,31/32"	OUT
			Arrow FORWARD					Arrow FORWARD				
Honda CR-V 30	12-	1375mm	M366 SUB0145	154mm	99mm	1071mm / 42,11/64"	OUT	M366 SUB0256	128mm	73mm	1019mm / 40,1/8"	OUT
			Arrow FORWARD					Arrow FORWARD				



DK284 Rhino-Rack VA, Aero, Euro & HD crossbar instruction

Measurement A: CENTRE of door jamb to CENTRE arrow of leg foot plate.

Measurement B: CENTRE of Front leg foot plate arrow to CENTRE of Rear leg foot plate arrow.

Carrying capacity: Roof rack is rated to 75kg. Please refer to manufacturers handbook for your vehicles maximum roof load capacity. Always use the lower of the two figures.

If your vehicle is not listed on this fitting instruction please refer to your countries Rhino-Rack web site for the latest information.

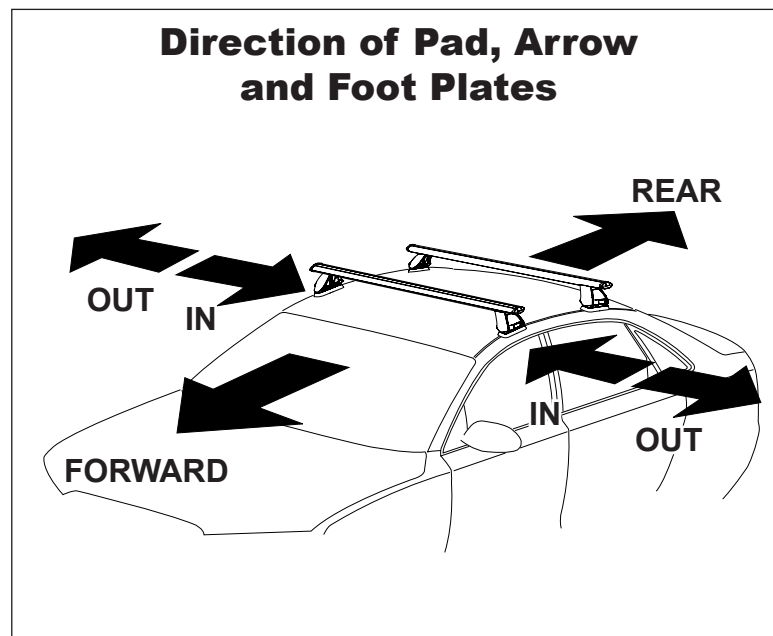
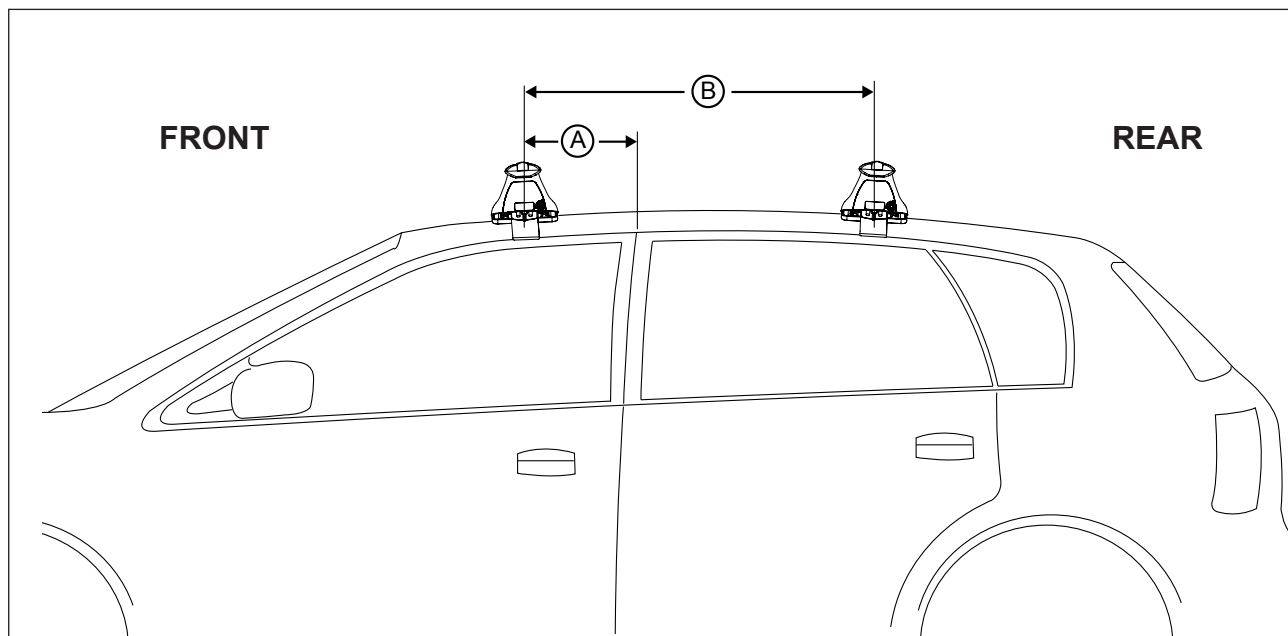

VEHICLE	Date	Measurement A	Measurement B	Load Rating (includes racks 5kg/ 11lbs)
Mitsubishi Challenger	12/09-	75mm / 3"	750mm / 29,17/32"	75kg / 165lbs
Mitsubishi Pajero Sport	10-	75mm / 3"	750mm / 29,17/32"	75kg / 165lbs
Honda CR-V 30	12-	300mm / 11,13/16"	750mm / 29,17/32"	75kg / 165lbs