



# DK106 Rhino-Rack VA, Aero, Euro & HD crossbar instruction

## IDENTIFICATION CHART



VA crossbar

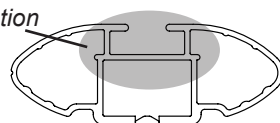

AERO crossbar



EURO crossbar

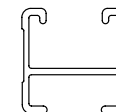

HD crossbar

Vehicle	Date	Crossbar	Front					Rear						
			Right Pad/ Clamp	Left Pad/ Clamp	Measurement strip length per side	Measurement strip length per side	Measurement Distance ( x )	Foot plate arrow direction	Right Pad/ Clamp	Left Pad/ Clamp	Measurement strip length per side	Measurement strip length per side	Measurement Distance ( x )	Foot plate arrow direction
Toyota Camry Wagon	02/93-04/98	1180mm	M365 SUB0182		175mm	120mm	918mm	OUT	M365 SUB0182		169mm	114mm	906mm	OUT
			Arrow FORWARD						Arrow FORWARD					
Holden Apollo Wagon	02/93-04/98	1180mm	M365 SUB0182		175mm	120mm	918mm	OUT	M365 SUB0182		169mm	114mm	906mm	OUT
			Arrow FORWARD						Arrow FORWARD					



# DK106 Rhino-Rack VA, Aero, Euro & HD crossbar instruction

**Measurement A:** CENTRE of door jamb to CENTRE arrow of leg foot plate.

**Measurement B:** CENTRE of Front leg foot plate arrow to CENTRE of Rear leg foot plate arrow.

**Carrying capacity:** Roof rack is rated to 75kg. Please refer to manufacturers handbook for your vehicles maximum roof load capacity. Always use the lower of the two figures.

If your vehicle is not listed on this fitting instruction please refer to your countries Rhino-Rack web site for the latest information.

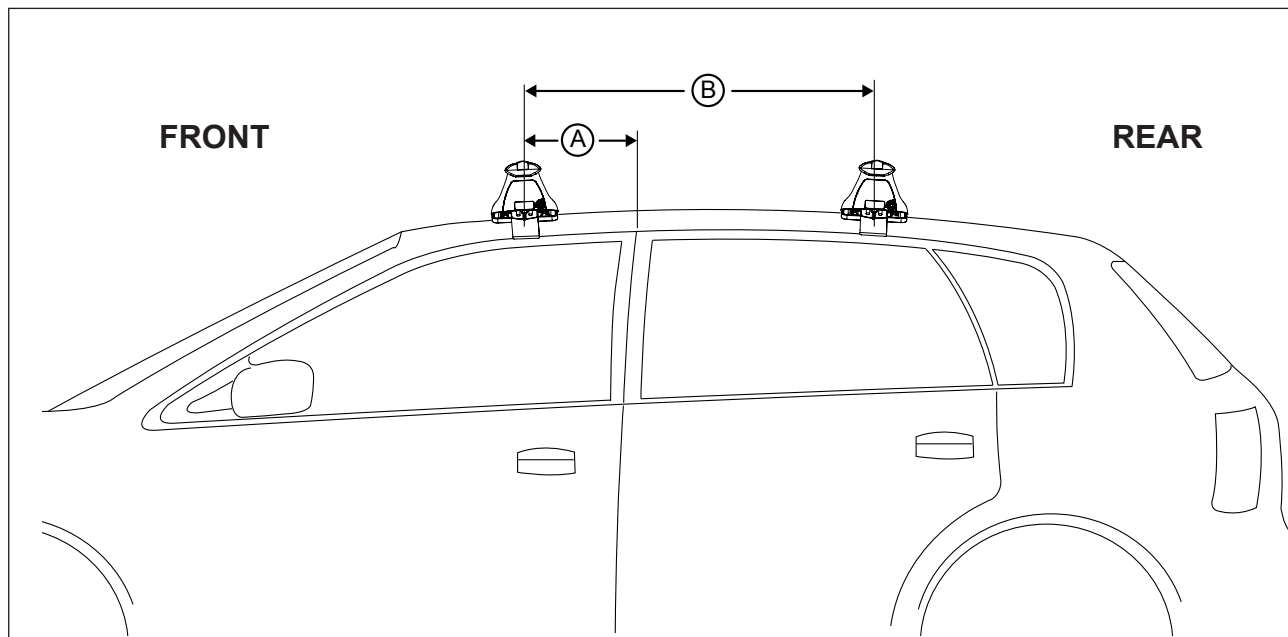

VEHICLE	Date	Measurement A	Measurement B	Load Rating (includes racks 5kg/ 11lbs)
Toyota Camry Wagon	02/93- 04/98	180mm	720mm	75kg / 165lbs
Holden Apollo Wagon	02/93- 04/98	180mm	720mm	75kg / 165lbs