

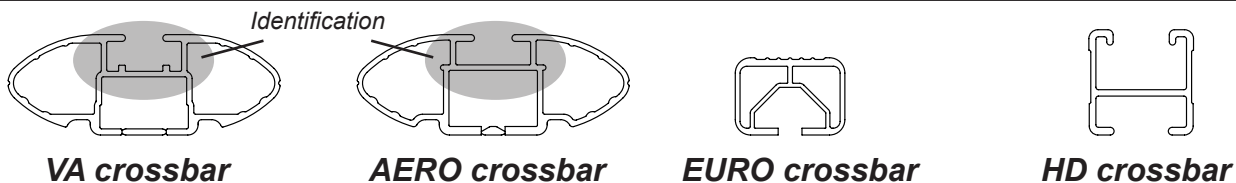

# DK030 Rhino-Rack VA, Aero, Euro & HD crossbar instruction

## IDENTIFICATION CHART



Vehicle	Date	Crossbar	FRONT CROSSBAR					REAR CROSSBAR						
			Front Right Pad/Clamp	Front Left Pad/Clamp	Measurement strip length per side	Measurement strip length per side	Measurement Distance (x)	Foot plate arrow direction	Rear Right Pad/Clamp	Rear Left Pad/Clamp	Measurement strip length per side	Measurement strip length per side	Measurement Distance (x)	Foot plate arrow direction
Honda Accord 4dr Sedan	03-07	1180mm	M368 SUB0148		185mm	130mm	938mm / 36,59/64"	OUT	M366 SUB0148		196mm	141mm	960mm / 37,51/64"	OUT
			Arrow OUT						Arrow FORWARD					
Subaru Impreza 5dr Hatch	07-11	1180mm	M368 SUB0148		186mm	131mm	940mm / 37"	OUT	M366 SUB0148		183mm	128mm	934mm / 36,49/64"	OUT
			Arrow OUT						Arrow FORWARD					
Subaru Impreza 4dr Sedan	08-11	1180mm	M368 SUB0148		186mm	131mm	940mm / 37"	OUT	M366 SUB0148		183mm	128mm	934mm / 36,49/64"	OUT
			Arrow OUT						Arrow FORWARD					



# DK030 Rhino-Rack VA, Aero, Euro & HD crossbar instruction

**Measurement A:** CENTRE of door jamb to CENTRE arrow of leg foot plate.

**Measurement B:** CENTRE of Front leg foot plate arrow to CENTRE of Rear leg foot plate arrow.

**Carrying capacity:** Roof rack is rated to 75kg. Please refer to manufacturers handbook for your vehicles maximum roof load capacity. Always use the lower of the two figures.

If your vehicle is not listed on this fitting instruction please refer to your countries Rhino-Rack web site for the latest information.

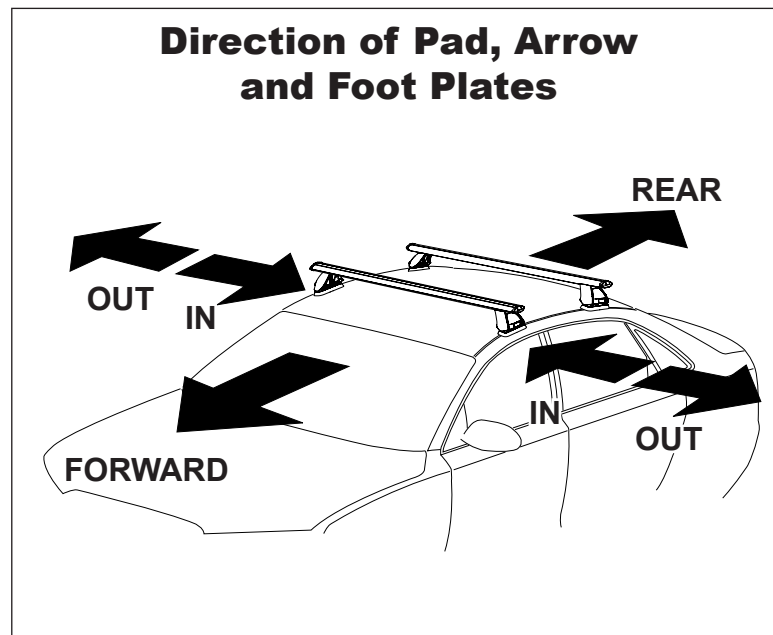
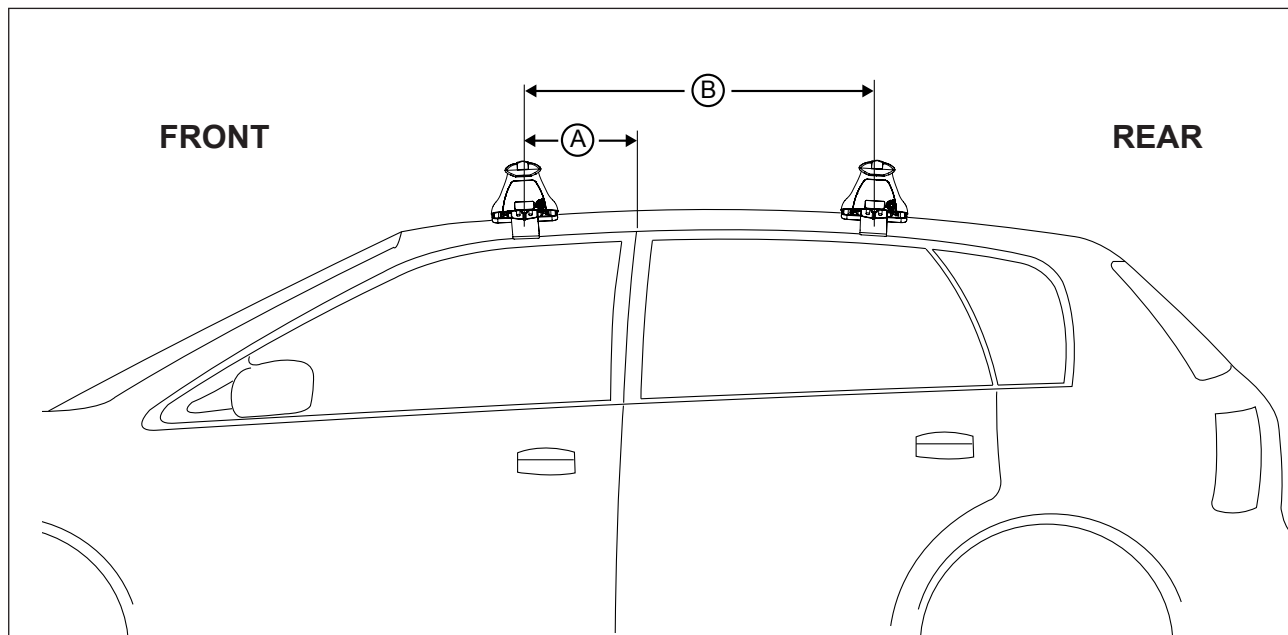

VEHICLE	Date	Measurement A	Measurement B	Load Rating (includes racks 5kg/11lbs)
Honda Accord 4dr Sedan	03-07	250mm / 9,27/32"	750mm / 29,17/32"	75kg / 165lbs
Subaru Impreza 5dr Hatch	07-11	150mm / 5,29/32"	650mm / 25,19/32"	75kg / 165lbs
Subaru Impreza 4dr Sedan	09-	150mm / 5,29/32"	650mm / 25,19/32"	50kg / 110lbs