



RHINO-RACK

Aerodynamic & Heavy Duty Roof Rack Systems

RTC12JW - Jeep Wrangler TJ 2 dr Canopy Rhino Track Mount

Important: Please read these instructions carefully prior to installation. Please refer to your fitting instruction to ensure that the roof racks are installed in the correct locations. Check the contents of kit before commencing fitment and report any discrepancies. Place these instructions in the vehicle's glove box after installation is complete.

Parts List

Maximum carrying capacity: 30kg

Item	Component Name	Qty	Part No.
1	RCP Track End Cap (RIGHT)	2	M177
2	RCP Track End Cap (LEFT)	2	M176
3	Rhino Track 1200mm	2	A256-1200
4	M6 x 25mm T-Bolt	10	B015
5	Knob & M6 Nyloc Nut	10	M175
6	6mm x 3mm O-ring	10	C347
7	Fitting Instruction	1	RR-141

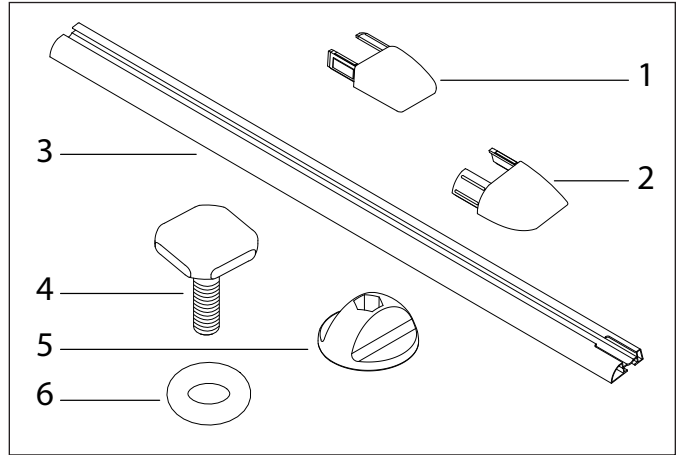

Care Instruction:

Clean the vehicle canopy prior to fitting the Rhino Tracks.

Tools Required

Vacuum cleaner.
Tape measure.
Pencil.
Power or Battery drill.
6.0mm drill bit.

Layout

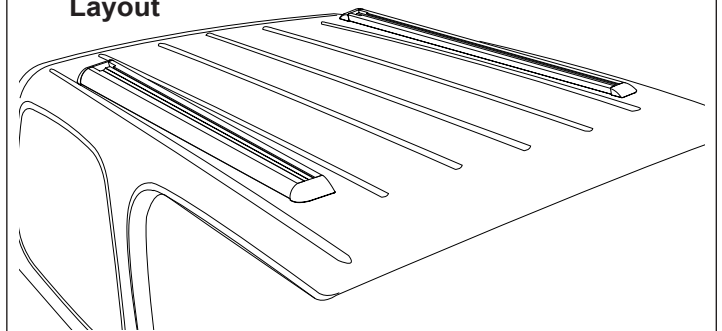

- 1** Using a pencil mark out a drilling centreline **60mm** from the edge of the 2nd roof channel in. Use one edge of the Track as a straight edge to rule a line (this will be the centreline of the Track). Using a Tape Measure plot 5 points taking each measurement from the small groove towards the rear of the canopy. Measure **85mm** from that same groove and place a line, this is where the end of the track will lie.

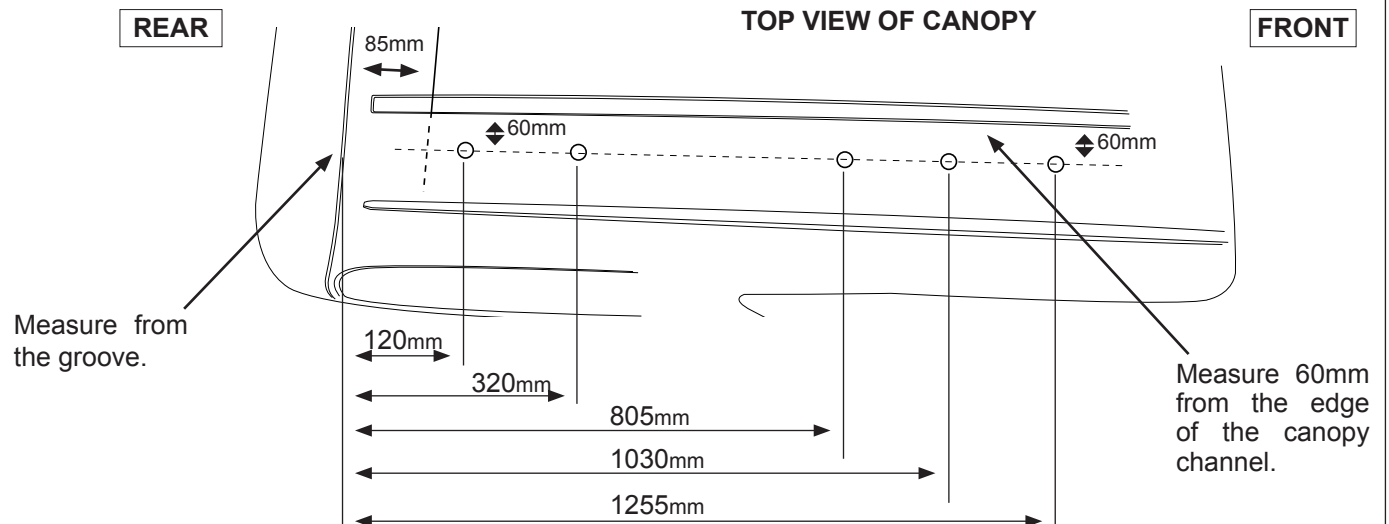



Jeep Wrangler Track Mount

2 Drill through the each of the 5 points marked using a 6.0mm drill bit, canopy is 4-5mm thick. Use care when breaking through the canopy. Vacuum fibreglass particles off canopy surface.

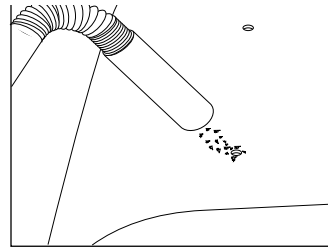
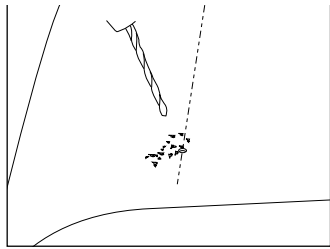

3 Install the rubber O-rings onto each T-bolt. Locate T-bolts in the C-groove on the underside of the track.

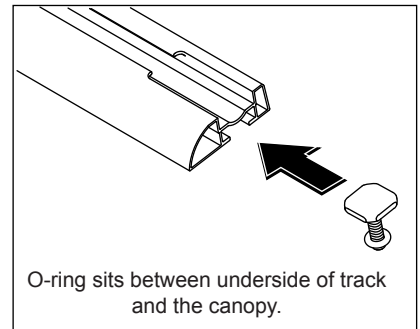
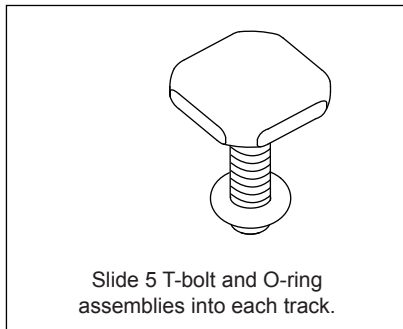
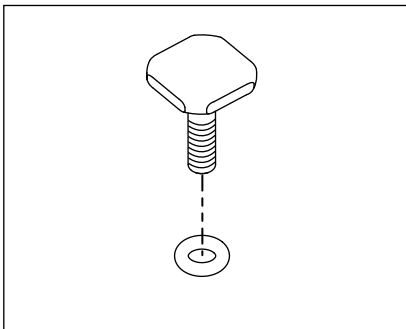

4 Insert the End caps into each end of the track. Peel the backing tape off the underside of the track.

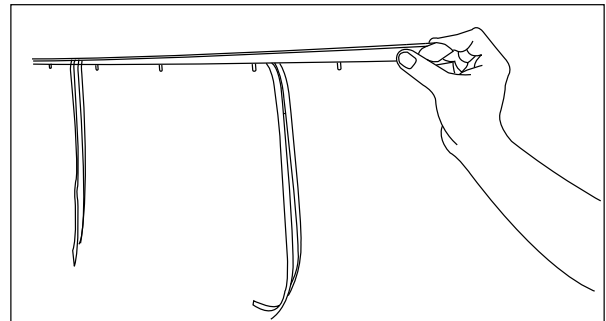
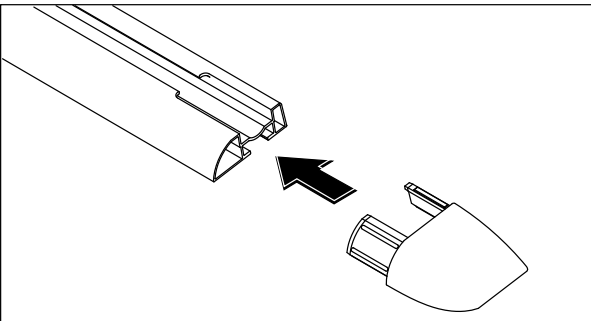

5 Align each T-bolt so that it drops into its corresponding hole position. The end of the track (*not the end cap*) must lie **85mm** from the groove towards the rear of the canopy.

Measure from groove.

85mm

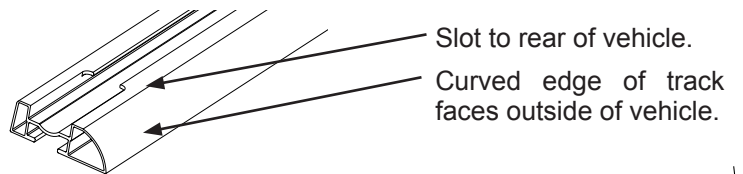
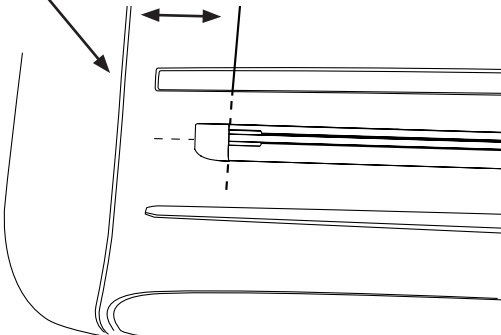



Jeep Wrangler Track Mount

- 6** Double check that all T-bolts have O-rings fitted. Gently finger tighten T-bolts only at this stage. Once all threads have been started tighten the centre knobs and work towards the ends. **DO NOT OVER TIGHTEN.**

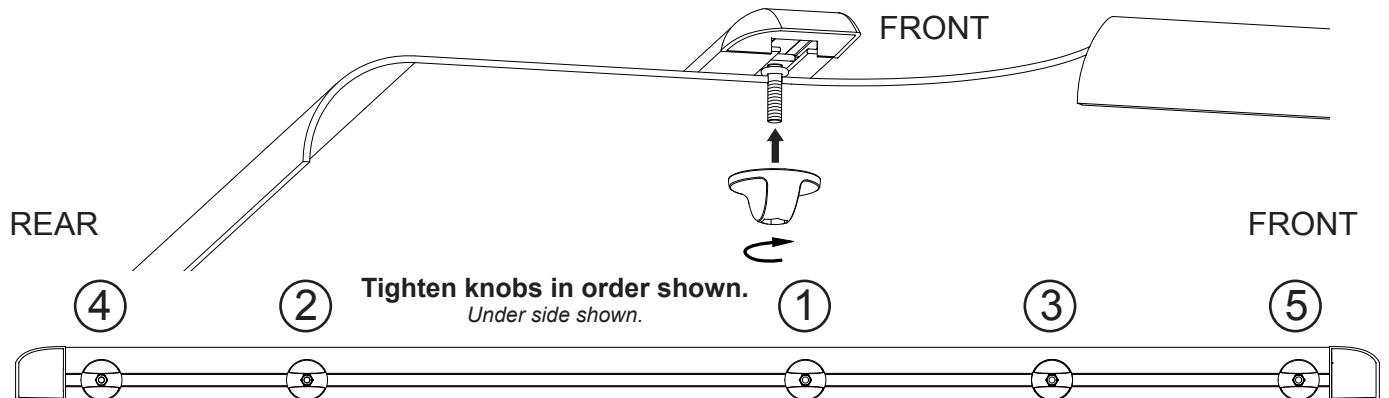

Important Information

Recommendations

It is essential that all bolt connections be checked after driving a short distance when you first install your crossbars. Bolt connections should be checked again at regular intervals (probably once a week is enough, depending on road conditions, usage, loads and distances travelled). You should also check the roof bars each time they are refitted. Make sure to fasten your load securely. Please ensure that all loads are evenly distributed and that the centre of gravity is kept as low as possible.

USE ONLY NON-STRETCH FASTENING ROPES OR STRAPS.

SENSITIVITY TO CROSSWINDS, BEHAVIOUR IN CURVES AND BRAKING.

The handling characteristics of the vehicle, changes when you transport a load on the roof. For safety reasons, we recommend you exercise extreme care when transporting wind-resisting loads; special consideration must be taken into account when braking.

PLEASE REMOVE CROSSBARS WHEN PUTTING VEHICLE THROUGH AN AUTOMATIC CAR WASH.

LOAD RATINGS

Maximum carrying capacity 30kg per pair of roof racks. When roof racks are to be used in extreme off road conditions please build a safety factor of 1.5 into the load rating. Although the roof racks are tested and approved to AS1235-2000, Australian road conditions can be much more rigorous. However, increasing the number of crossbars does not increase the vehicles maximum permissible roof loading.

IMPORTANT NOTE FOR DEALERS AND FITTERS

Rhino-Rack cannot be held responsible for incorrect mounting of units or usage that exceeds production tolerance. If any of these fitting instructions are unclear to you, the fitter, please contact Rhino-Rack. It is your responsibility to ensure the instructions are given to the end user or client.

Rhino-Rack
3 Pike Street, Rydalmere,
NSW 2116, Australia.
(Ph) (02) 9638 4744
(Fax) (02) 9638 4822

Document No: RR-141
Prepared By: Craig Jones
Authorised By: Gary England

Issue No: 02
Issue Date: 04/09/2008

These instructions remain the property of Fetovu Pty Ltd T/as Rhino-Rack and may not be used or changed for any other purpose than intended.